

**Douglas County Board of Commissioners
Resolution Number 2014R-080**

A resolution adopting an amendment to the Douglas County Design Criteria and Improvement Standards Manual, Part I, Division 7, to include the Tahoe Design Standards and Guidelines which replaces the South Shore Design Standards and Guidelines, providing design guidelines for nonresidential uses in both the South Shore Area Plan and the Tahoe Douglas Area Plan, and replacing the Design Standards for the Round Hill Community Plan

WHEREAS, on December 12, 2012, the TRPA Governing Board adopted an update to the TRPA Regional Plan and TRPA Code of Ordinances, including Chapter 13, *Area Plans*, which allows for an Area Plan to include additional or substitute community design standards that address, among other things, site design, building height, building design, landscaping, lighting, and signing; and

WHEREAS, on September 13, 2013, the Board of Commissioners adopted an update to the Douglas County Design Criteria and Improvement Standards Manual, Part I, Planning Design Criteria, to include a new Division 7: South Shore Design Standards and Guidelines to implement the South Shore Area Plan in order to meet the community design requirements in Chapter 13, *Area Plans*, of the TRPA Code of Ordinances and build upon the concepts developed in the South Shore Vision Plan; and

WHEREAS, in May 2013, the Board of Commissioners directed staff to bring forward a new Area Plan (phase 2) and related design standards for the remaining portion of properties within Douglas County, within the Tahoe Basin and outside of the South Shore Area Plan; and

WHEREAS, the Community Development Department, on behalf of the Planning Commission and Board of Commissioners, entered into a contract with Design Workshop to develop the Tahoe Design Standards and Guidelines which will replace the South Shore Design Standards and Guidelines, providing design guidelines for nonresidential uses in both the South Shore Area Plan and the Tahoe Douglas Area Plan, and replacing the Design Standards for the Round Hill Community Plan; and

WHEREAS, the Community Development Department developed a webpage to gather public input on the draft Tahoe Design Standards and Guidelines; and

WHEREAS, on October 14, 2014, the Planning Commission held a public hearing, took public comment and voted to recommend approval of the Tahoe Design Standards and Guidelines to the Board of Commissioners, and

WHEREAS, on October 16, 2014, the Board of Commissioners held a public hearing and took public comment on the Tahoe Design Standards and Guidelines; and

WHEREAS, the Board of Commissioners has determined that an amendment to the Douglas County Design Criteria and Improvement Standards Manual, Part I, Division 7: Tahoe Design Standards and Guidelines is necessary to encourage environmental redevelopment and help bring the area into Scenic Threshold attainment; and

WHEREAS, the TRPA Code of Ordinances, Chapter 13, *Area Plans*, requires the Area Plan to be approved by the Douglas County Board of Commissioners prior to the TRPA Governing Board's review and finding of conformance. Pursuant to TRPA Code of Ordinance §13.6.4, this Resolution cannot take effect until the TRPA Governing Board has approved the Area Plan and made a finding of conformance. All plans, policies and regulations in the TRPA Regional Plan, TRPA Code of Ordinances, Douglas County Code, Douglas County zoning maps, and Douglas County Design Criteria and Improvement Standards manual remain in effect until superseded by a TRPA and Douglas County approved Area Plan. Following TRPA Governing Board's finding of conformance, Douglas County's limited development permitting authority within the Area Plan is contingent upon and subject to TRPA and Douglas County entering into a Memorandum of Understanding (MOU).

NOW, THEREFORE, BE IT RESOLVED that the Douglas County Board of Commissioners hereby adopt the following in compliance with Division 1.0 of the Douglas County Design Criteria and Improvement Standards:

1. Approve and amend the Douglas County Design Criteria and Improvement Standards Manual, Part I, Division 7, Tahoe Design Standards and Guidelines, as attached as "Exhibit A" including changes recommended by staff.

2. The adopted, Division 7, Tahoe Design Standards and Guidelines shall become effective and enforced as of the date of Resolution 2014R-080 adoption and the effective date of the Douglas County Code, Chapter 20.700 Tahoe Area Plan Regulations following TRPA Governing Board's review and approval of the Area Plan as approved by the Douglas County Board of Commissioners.

Adopted the 16th day of October 2014 by the following vote:

AYES: BARRY PENZEL

 DOUG N. JOHNSON

 LEE BONNER

 GREG LYNN

 NANCY MCDERMID

NAYS: NONE

ABSENT: NONE

ABSTAIN: NONE

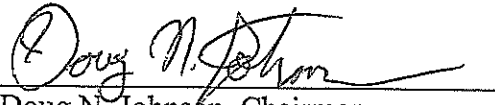

Doug N. Johnson, Chairman
Douglas County Board of Commissioners

ATTEST: *Shirley Suddles* for
Douglas County Clerk-Treasurer

EXHIBIT A



TAHOE
DESIGN STANDARDS AND
GUIDELINES
DOUGLAS COUNTY, NEVADA
DRAFT

Prepared For:
Douglas County and the Tahoe
Regional Planning Agency



Prepared By:
DESIGNWORKSHOP

Divison 7: Table of Contents

- 1. INTRODUCTION
 - 1.1 PURPOSE AND APPLICABILITY 1
 - 1.2 INTENT OF DESIGN STANDARDS AND GUIDELINES 3
 - 1.3 DOCUMENT ORGANIZATION..... 3

- 2. SITE LAYOUT
 - 2.1 BUILDING ARRANGEMENT AND LOCATION 5
 - 2.2 CIRCULATION AND PARKING 9
 - 2.3 PARKING STRUCTURES 11
 - 2.4 VEHICULAR ACCESS 11
 - 2.5 PEDESTRIAN ACCESS 12
 - 2.6 BICYCLE ACCESS 14
 - 2.7 OPEN SPACE AREAS 14
 - 2.8 SNOW STORAGE 15

- 3. LANDSCAPE DESIGN
 - 3.1 GENERAL 17

- 4. BUILDING DESIGN
 - 4.1 GENERAL 19
 - 4.2 COMMERCIAL, INSTITUTIONAL AND MIXED-USE BUILDING ELEVATIONS 22
 - 4.3 INDUSTRIAL BUILDING ELEVATIONS 24
 - 4.4 ROOFS..... 24
 - 4.5 MULTIPLE TENANT BUILDINGS 24

- 5. SIGNS
 - 5.1 GENERAL 25
 - 5.2 MULTIPLE TENANT BUILDINGS 26
 - 5.3 WALL SIGNS 26
 - 5.4 MONUMENT SIGNS 27
 - 5.5 POINTS OF INTEREST (WAYFINDING) AND COMMUNITY ENTRY SIGN..... 27

- 6. LIGHTING
 - 6.1 GENERAL 29

- 7. SCREENING
 - 7.1 GENERAL 33
 - 7.2 WALLS AND FENCES..... 34

1. INTRODUCTION

1.1 Purpose and Applicability

The purpose of the Tahoe Design Standards and Guidelines is to enhance the existing experience within the Douglas County portion of the Tahoe Basin, improve the economic viability of the area and direct future development in ways that are responsive to the specific environmental conditions and natural setting of the Tahoe Region.

Beyond the general goals articulated above, it is the purpose of these standards and guidelines to comply with the Tahoe Regional Planning Agency Code of Ordinances requirements for a Conforming Area Plan. Among the required contents for Area Plans are Community Design Standards that address the fundamental areas of the development process including; Site Design, Building Height, Building Design, Landscaping, Lighting and Signing.

The Tahoe Design Standards and Guidelines are specifically tailored to the region of Douglas County within the Tahoe Basin. The standards and guidelines will assist landowners, developers, tenants, and their consultants, such as architects, who propose any

alteration, addition, construction, and/or development projects within the boundaries of either the South Shore Area Plan or the Tahoe Douglas Area Plan (see Image 2). In combination with the TRPA Code of Ordinances and the Douglas County Development Code, the Tahoe Design Standards and Guidelines are intended to convey the community's vision for the quality and character of the built environment. The design standards and guidelines are applicable to commercial, industrial, institutional, mixed-use and multi-family projects and buildings. Single-family residential projects shall be developed according to the requirements of the TRPA Code of Ordinances and the Douglas County Development Code, but do not need to comply with the standards and guidelines contained herein.

Douglas County and/or Tahoe Regional Planning Agency (TRPA) staff shall use the following standards and guidelines to review projects for 1) compliance with the intent of the design guidelines, and 2) compliance with the design standards. Individuals and entities proposing projects within either the South Shore Area Plan or Tahoe Douglas Area Plan boundary shall review these standards and guidelines before initiating the design and development process. To facilitate project approvals, questions regarding the design standards and guidelines, as well as other development-related questions, shall be discussed with the Douglas County Community Development staff as early in the development process as possible.



Image 1. The Tahoe Design Standards and Guidelines are intended to convey the community's vision for the quality and character of the built environment.

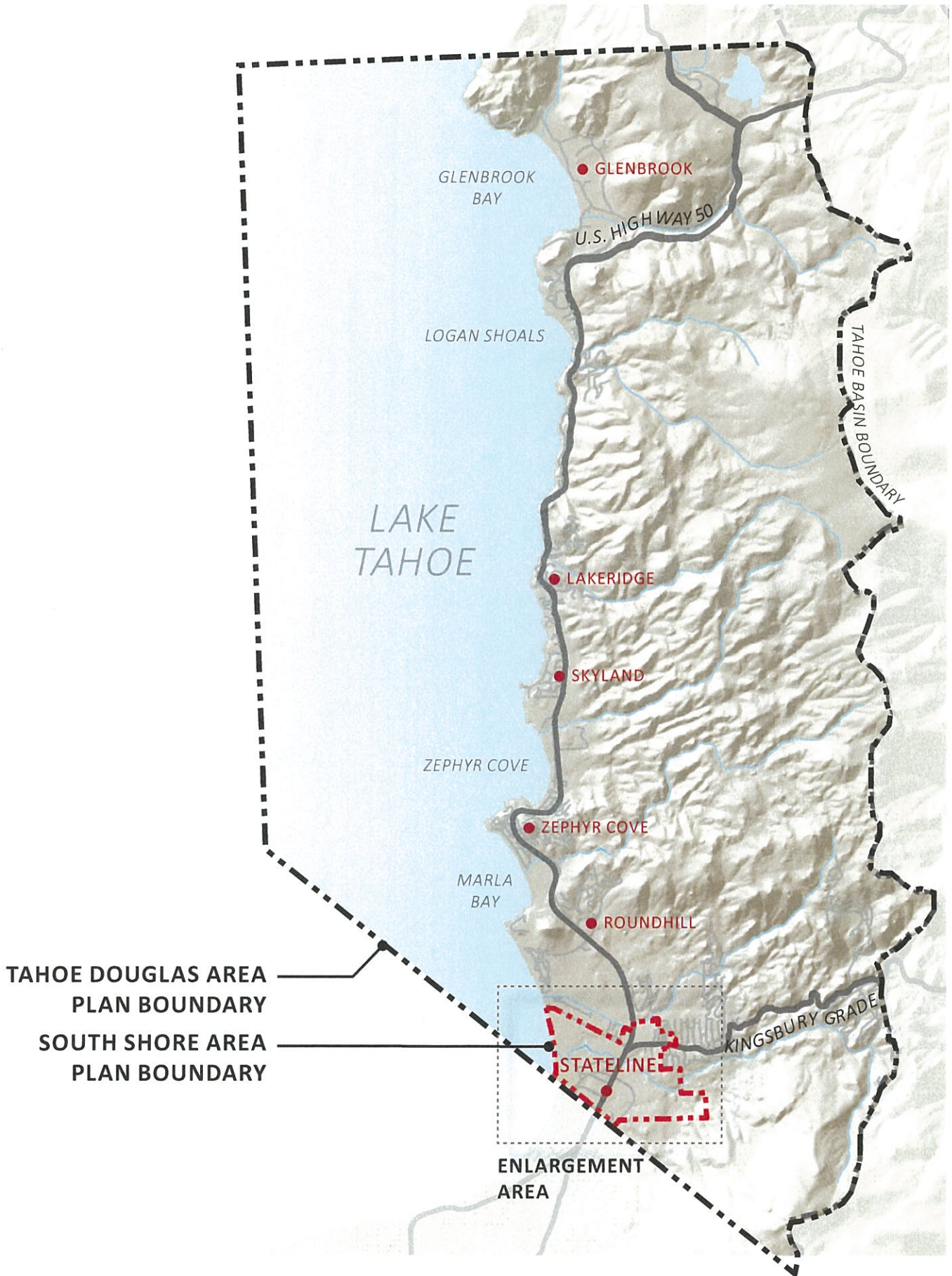

Image 2. Douglas County Area Plan boundaries.

1.2 Intent of Design Standards and Guidelines

These design standards and guidelines are intended to enable design professionals to prepare plans for both public and private projects. The design standards and guidelines relate to aesthetic consideration of project development. They are not intended to inhibit innovative design. Projects must also comply with other codes, i.e., the TRPA Code of Ordinances and the Douglas County Development Code. Nothing herein alters the provisions of Article VI of the Compact related to gaming. These design standards and guidelines describe how to aesthetically and sensitively refine the code and development requirements into a project that is compatible with the mountain environment, considerate of community's objectives and responsive to the specific environmental issues in the Tahoe Region. For example, there are codes that establish the parameters for height and coverage, however, they do not describe how to aesthetically and sensitively apply them to a site. This manual provides the guidance to accomplish this.

1.3 Document Organization

Each section of the Tahoe Design Standards and Guidelines begins with a statement to convey the overarching design intent followed by the specific standards and guidelines intended to achieve the desired character and design quality. Additionally, specific design standards and guidelines have been developed for areas within the Town Center and High-Density Tourist Districts to promote multi-modal transportation, encourage walkability, address unique building design and to facilitate environmental quality improvements.

To differentiate what is required vs. what is recommended this document identifies both standards and design guidelines. Guidelines are recommendations that support the overarching goals. Guidelines are not required for approval and therefore use terms such as "may," "encourage," "should," and "to be considered." Standards describe features and qualities which are mandated and measurable. Standards use the terms "shall" and "must" to indicate that compliance is required.

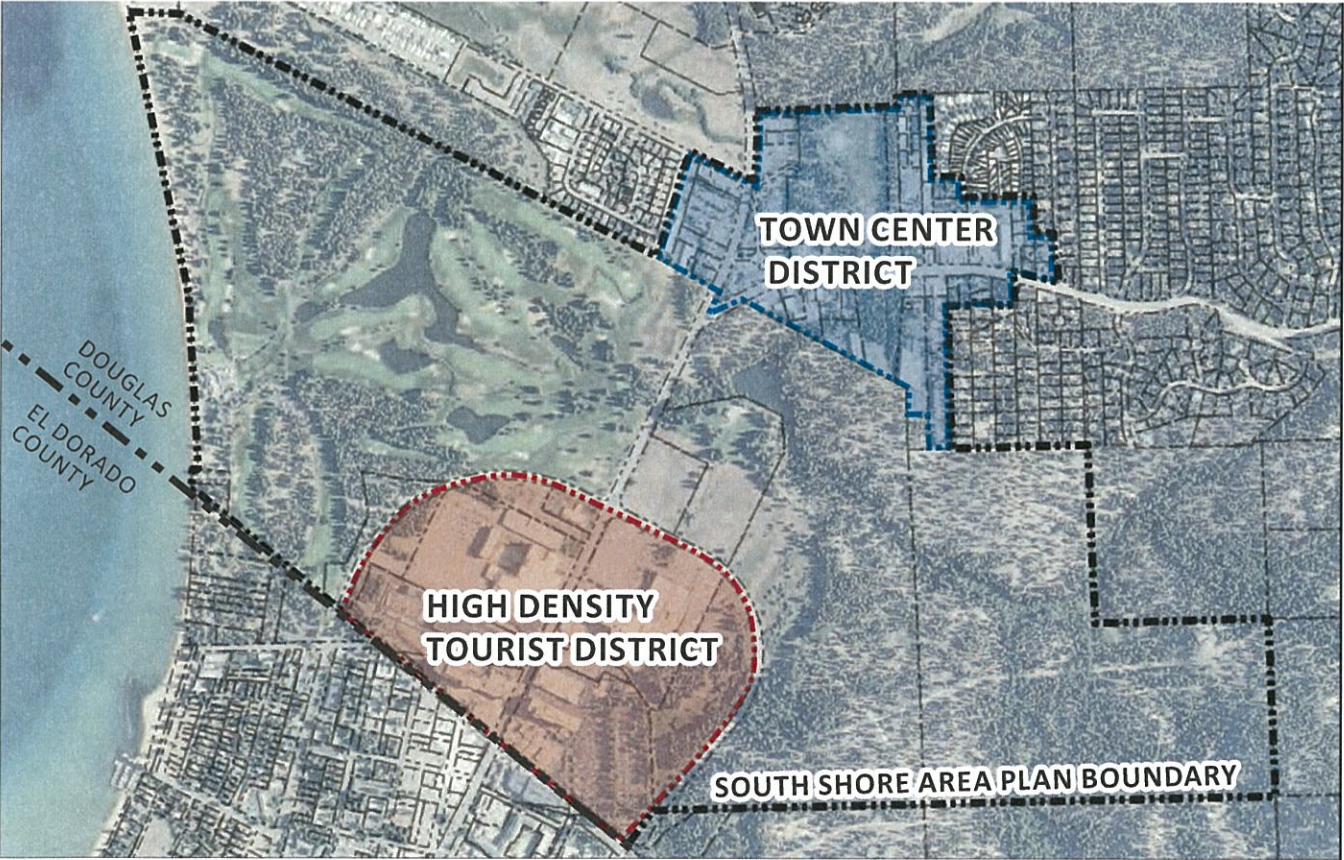

Image 3. Additional design standards and guidelines have been developed to support the goals and policies within special planning districts.

2. SITE DESIGN

Site layout involves the arrangement of indoor and outdoor spaces to accommodate the activities related to the proposed uses. Customer service, vehicle movement patterns, loading needs, and expansion potential should all be considered when establishing the site design. A site functions as an integral part of the community and site design should organize the spaces and activities based on a site's programmatic requirements as well as broader community objectives. The design should take into account factors such as safety, privacy, community identity and character, and preservation of the natural environment.

2.1 Building Arrangement and Location

The arrangement and location of buildings greatly influences the experiences and operational characteristics of a site. Consideration should be given to all the aspects of the site; the physical characteristics, environmental conditions, and social expectations to determine the arrangement and location for buildings that will provide the greatest benefit. Well organized buildings can create comfortable pedestrian plazas, promote walkability, encourage commerce, improve building performance and reinforce community identity.

- 2.1.1 Mixed-Use buildings shall be oriented with the primary entry and façade toward the street or the primary drive aisle.
- 2.1.2 In multi-building commercial and private recreational developments, the buildings shall be clustered creating pedestrian shopping

plazas, corridors and open spaces. Where clustering is impractical, a visual link between the buildings shall be incorporated. This link can be accomplished by the use of an arcade system, trellises or other similar open structures.

- 2.1.3 Buildings shall be located in a manner that will complement adjacent structures and properties. Sites should be developed in a coordinated manner to provide order and diversity, and avoid an "unplanned" development look.
- 2.1.4 Loading areas or docks shall be located to the rear or the side of the building, away from public rights-of-way, and cannot interfere with the on-site circulation. All loading and unloading shall take place on site. Street servicing is discouraged. The loading areas/docks shall be designed so their visibility is minimal by using features such as wing walls and landscaping. The location and orientation of the building must consider accessibility to the loading areas.



Image 4. Organizing buildings and entry points towards the street encourages an active streetscape with opportunities for interesting gathering places.

- 2.1.5 Automotive repair/service buildings or other uses which provide mechanical services should be arranged so that the bay entries/exits are not fronting a primary street.
- 2.1.6 The existing natural features on a site such as trees, slopes and rock outcroppings should be retained and incorporated into the site layout to create more interesting and unique designs that are integrated with the natural existing environment.
- 2.1.7 Buildings shall be designed and sited with consideration of solar exposure, climate, noise, safety, fire protection and privacy. Outdoor spaces shall be designed to create interesting gathering spaces with opportunities for year-round event programming.
- 2.1.8 Setbacks shall be consistent with the Tahoe Area Plan Regulations (Chapter 20.703 in the Douglas County Development Code).
- 2.1.9 Detached storage buildings, service yards, maintenance yards, warehousing and outdoor storage areas shall be located in areas that are not highly visible from major transportation corridors, scenic turnouts, public recreation areas, or the waters of Lake Tahoe.
- 2.1.10 Buildings must be arranged or designed so that they do not create a “blind corner” and/or impair visibility. Specific consideration

and design alternatives must be evaluated for corner lots and instances where there are existing and adjoining driveways.

- 2.1.11 Site plans are encouraged to incorporate Low Impact Development techniques to reduce the impact of built areas and promote naturally functioning systems. The following practices may be integrated with the overall design of landscape areas to combine the functions of storm water treatment with aesthetically pleasing landscape features:

- a. *Pervious pavement materials that allow water to pass through the paving and infiltrate into the ground are encouraged for pedestrian applications. Other pavement surfaces may incorporate pervious pavements but shall be designed in conjunction with the site's Best Management Practices (BMPs).*
- b. *Preserving existing trees should be planned for with a focus on preserving large groups of forest rather than individual trees that are subjected to changes of runoff, grades, or surface coverage. The protection zone for trees extends to the drip-line of the tree's canopy.*
- c. *As part of surface water management, small areas of infiltration catchments are to be incorporated into the final contour of the landscape. These features will offer the reduction in run-off from each site.*



Image 5. Outdoor gathering places with opportunities for year-round event programming will help to establish a pedestrian oriented experience.

- 2.1.12 Building design and placement should preserve and enhance views from public areas towards Lake Tahoe and mountain ridge lines.
- 2.1.13 Building design and placement shall promote a visual balance between the various elements both on and adjacent to the site. Building arrangements shall neither create monotonous or overpowering forms nor should they dominate the visual composition.
- 2.1.14 New buildings adjacent to existing lower scale residential development shall respect the scale and privacy of adjacent properties by varying the massing within a project and incorporating architecture designs and building treatments that transition to smaller scale buildings.

STANDARDS AND GUIDELINES FOR TOWN CENTER DISTRICT

(In addition to those identified previously, the following standards and guidelines apply to properties within Town Centers)

- 2.1.15 Properties along US Highway 50 with ground level retail and commercial uses shall provide primary pedestrian access directly to the street. The intent of this retail/pedestrian street requirement is to present a dynamic, fragmented street front to outdoor spaces, rather than uniform blocks of building mass.



Image 6. Preserving existing trees and incorporating naturally functioning systems into the site design is integral to the establishing the aesthetics of the place.



Image 7. Building heights and arrangements that preserve and enhance view corridors helps to blend the built environment with the surrounding natural conditions.

STANDARDS AND GUIDELINES FOR HIGH-DENSITY TOURIST DISTRICT

(In addition to those identified previously, the following standards and guidelines apply to properties within the High-Density Tourist District)

- 2.1.16** Buildings that are 8 stories or higher, should be sited so their longest frontages are perpendicular to the primary street. Lower buildings located on the primary street frontage are encouraged to address the street so that their longest frontage is parallel to the street edge.
- 2.1.17** The travel route of Hwy 50 has a “canyon effect” because the existing tower structures are located too close together with inadequate setbacks. Within a given property, 80% of the buildings fronting Hwy 50 shall not exceed 56 feet in height when an existing building or buildings are being replaced within 100 feet of the right-of-way. 20% of the building or buildings frontage may be constructed to a maximum height of 95 feet. Redeveloped towers up to the maximum allowable height shall be sited behind buildings fronting on Hwy 50. Lower buildings at the street level will reduce the visual dominance of the towers and improve the visual condition along the Highway 50 travel route by creating a pedestrian scale street section by shifting the tower height away from the immediate area of the street. Existing buildings with non-

conforming height are allowed to do frontage improvements up to their existing height.

- 2.1.18** Redevelopment of the existing towers is contingent on the creation of new and additional open space that will replace a portion of the surface parking with a landscape setting. Additional open space would improve the travel route rating with the development of a visually attractive landscape.



Image 8. Lower buildings located parallel to the street edge establish a pedestrian scaled street section.



Image 9. Redevelopment of the existing towers associated with gaming properties will be accompanied by new and additional open space to help bring the area into scenic threshold attainment.

2.2 Circulation and Parking

Circulation and parking establish the pattern of movement for pedestrians, bicyclists, trucks and automobiles. The design of the circulation system on a site is critical to creating safe travel routes between parking areas and building entrances. Simple layouts which can be readily understood by motorists are advocated.

- 2.2.1 The on-site circulation must be logical and provide convenient, safe and direct flow of pedestrians and vehicles.
- 2.2.2 All parking areas, driveways, parking aisles and sidewalks shall be graded, drained and paved in accordance with the Development Code and Part II of the Douglas County Design Criteria and Improvement Standards.
- 2.2.3 New surface parking areas are discouraged within view of US Highway 50. New parking areas should be situated behind buildings and screened from street views.
- 2.2.4 Parking aisles should be arranged to direct pedestrians parallel to moving cars thereby minimizing the need for pedestrians to cross parking aisles and landscape areas. As an alternative, separated pedestrian walkways

should be incorporated in the parking lot design.

- 2.2.5 Whenever parking areas/drive aisles are connected to adjacent sites, the circulation must provide for similar direction of travel (both vehicular and pedestrian) and parking stalls to reduce conflict at points of connection.
- 2.2.6 To promote efficient and safe vehicular and pedestrian circulation, curb cuts and private driveways should be kept to a minimum.
- 2.2.7 In cases where one-way traffic aisles are provided, one-way traffic signs shall be clearly posted and one-way arrows shall be painted and maintained within the drive aisle.
- 2.2.8 The turning radii for drive aisles and loading areas shall meet the AASHTO standards for turning movements.
- 2.2.9 Parking spaces abutting structures must be separated by a 6 foot wide sidewalk or landscape planter.
- 2.2.10 Parking stalls shall be located so that vehicles do not back-up into primary ingress driveways. The first parking stall parallel to a driveway shall be separated by a landscape planter a minimum of 20 feet in width, one car length.



Image 10. Safe and convenient circulation systems will help ensure the safety of pedestrians and motorists.

- 2.2.11 Loading/unloading areas shall be clearly identified by installing no parking signs and/or striping of the space. The areas must be located in the rear or the sides of the building and shielded so that they are not visible from the street.
- 2.2.12 Parking areas abutting properties residentially used or designated shall be separated by a landscape buffer a minimum of 10 feet in width. In addition to landscaping, perimeter earth bearming is recommended as an effective way to reduce the visual impact of surface parking lots.
- 2.2.13 All parking and drive aisles shall be designed to provide sufficient emergency vehicle access and maneuverability.
- 2.2.14 All parking shall comply with the most current American with Disabilities Act (ADA) standards and regulations.
- 2.2.15 Establishments that typically require or generate frequent passenger loading and unloading shall provide specifically designated loading/unloading stopping bays. Direct ingress and egress should be provided so that vehicles are not directed into the on-site drive aisles.
- 2.2.16 The number of required parking and loading spaces shall be consistent with the Tahoe Area Plan Regulations (Chapter 20.703, Parking and Loading).
- 2.2.17 Parking lots shall be located and designed with BMPs to capture, treat and infiltrate storm water.

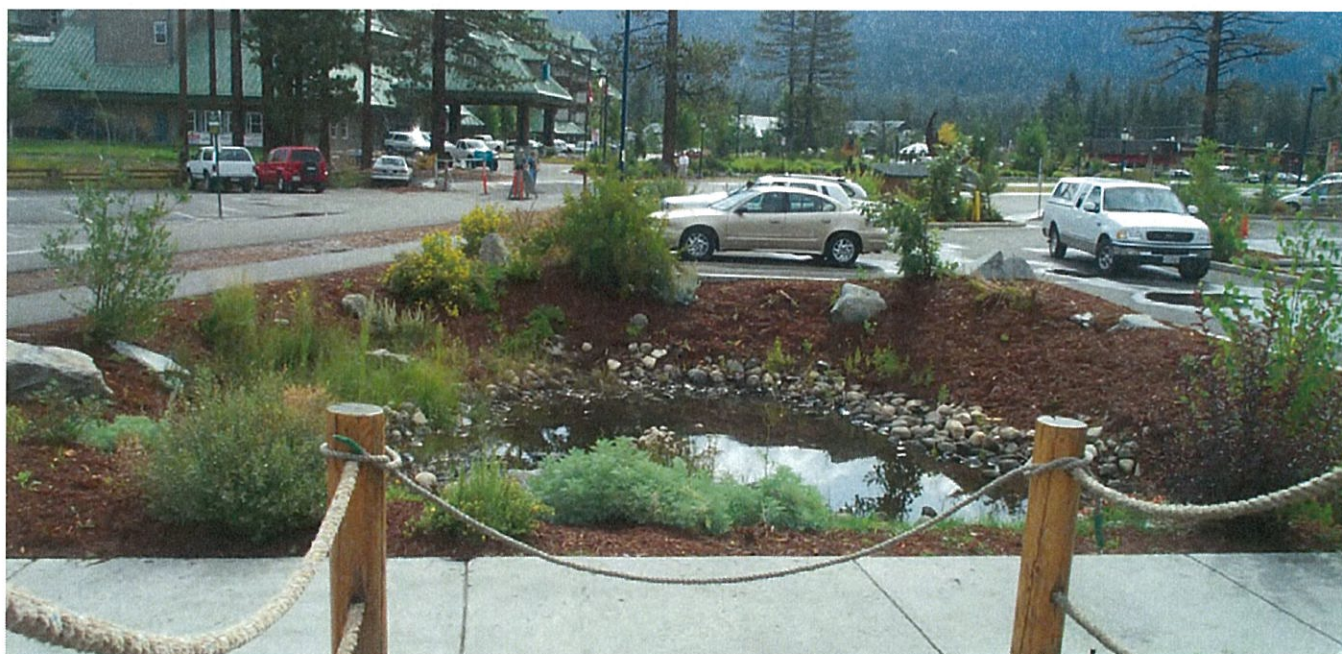

Image 11. Best Management Practices (BMPs), such as infiltration basins, provide an aesthetically pleasing and lower cost alternative to conventional storm water treatment strategies.

2.3 Parking Structures

Structured parking is encouraged as a means of reducing overall site coverage and where parking demand necessitates such a solution. Structures should be intuitively located without visually dominating a project.

- 2.3.1 The exterior surface materials of the parking structure must be compatible and complementary to the main structure.
- 2.3.2 The exterior façade facing a public right-of-way must be articulated by the use of one or more of the following features; complementary colors, stepping of floors, arrangement of façade elements and/or alternative building materials.
- 2.3.3 Solid screening elements shall be provided on a portion of each floor of the parking structure to sufficiently screen parked vehicles. Ground floor screening elements shall include landscape planters.
- 2.3.4 A minimum 5-foot wide landscape planter area shall be provided between the structure and a road, sidewalk or internal drive aisle. The planter shall include live plant material including but not limited to shrubs, trees, and vines.
- 2.3.5 The location of entrance and exit driveways shall be located/ designed so that the impacts to vehicular and pedestrian traffic are minimized to the extent possible. Exit driveways shall be designed so that “blind corners” are avoided.
- 2.3.6 Sidewalks must be provided along the full length of buildings featuring customer entrances and along any façade facing public parking areas.

STANDARDS AND GUIDELINES FOR HIGH-DENSITY TOURIST DISTRICT

(In addition to those identified previously, the following standards and guidelines apply to properties within the High-Density Tourist District)

- 2.3.8 Locate new parking structures so they do not interfere with the opportunity to create a pedestrian oriented streetscape. Access to parking structures from US Hwy. 50 is allowed, but parking only structures fronting US Hwy. 50 are strongly discouraged.

2.4 Vehicular Access

The point where a driver enters or leaves a site affects both a project and the community as a whole. Care must be taken in locating access to avoid creating traffic hazards where drivers are entering or leaving a site. In addition, poor placement or an insufficient number of access points to a site can lead to their blockage and impede smooth traffic flow through a site.

- 2.4.1 Vehicular access points shall be kept to a minimum. However, the number and location of driveway curbs must be adequate to allow efficient traffic flow. Joint access between adjacent sites shall be utilized whenever possible to reduce traffic hazards and necessary curb cuts.
- 2.4.2 Driveways are to be designed and located to meet the AASHTO standards for turning movements.
- 2.4.3 The distance between driveways and intersection corner clearance must be consistent with the standards provided in Part II, Engineering Design and Criteria and Improvement Standards of the Douglas County Design Criteria and Improvement Standards.
- 2.4.4 Two-way traffic along Hwy 50 (or Main Street when Hwy 50 is realigned) is encouraged.



Image 12. Relocate and screen parking structures to create a pedestrian oriented main street.

2.5 Pedestrian Access

A safe and convenient pedestrian circulation system guarantees that people of all abilities can move around on the site and between properties throughout the year.

- 2.5.1 All sidewalks shall be constructed of Portland cement concrete, unit pavers or other similar concrete material.
- 2.5.2 Separate vehicular and pedestrian systems shall be provided. Pedestrian linkages between uses within development, surrounding developments and trails/bikeways shall be provided and emphasized, including distinct pedestrian access from parking areas to the building. Walkways should include enhanced paving, trellis structures or enhanced landscaping treatments. A continuous and direct sidewalk shall be provided from the street to the on-site sidewalk.
- 2.5.3 Sidewalks should be provided along the full length of the building featuring customer entrances and along any façade facing public parking areas.
- 2.5.4 On-site sidewalks must be a minimum of 4-feet wide. When parking stalls directly abut a sidewalk, the sidewalk shall be a minimum of 6-feet wide. If exterior stairways are used with the stairway landings on the sidewalk, the sidewalk shall be a minimum of 6-feet wide.
- 2.5.5 All pedestrian areas shall comply with the most current American with Disabilities Act (ADA) standards and regulations. Particular attention shall be given to ramps, accessible paths of travel, level landings and handrails.
- 2.5.6 Hotel, resort and institutional uses which have frequent loading and unloading of passengers are to provide a port-cochere or other similar feature at the passenger loading/unloading area.

STANDARDS AND GUIDELINES FOR TOWN CENTER DISTRICT

(In addition to those identified previously, the following standards and guidelines apply to properties within Town Centers)

- 2.5.7 Site designs and building arrangements shall promote pedestrian activity by providing enhanced design features along public roadways. Enhanced design features to be



Image 13. Simple concrete sidewalks accentuated with landscaping provide pleasant connections for pedestrians.



Image 14. Sidewalks shall be provided along the full length of building featuring customer entrances.



Image 15. Design elements such as increased setbacks and increased building articulation help create a comfortable zone for pedestrians.

considered include increased setbacks, stepped heights, increased building articulation, and/or higher quality building materials.

- 2.5.8 Promote alternative transportation modes such as walking, bicycling, transit use, and shared parking strategies which at a minimum shall include continuous sidewalks or other pedestrian paths and bicycle facilities along both sides of all highways with connections to other major activity centers.

STANDARDS AND GUIDELINES FOR HIGH-DENSITY TOURIST DISTRICT

(In addition to those identified previously, the following standards and guidelines apply to properties within the High-Density Tourist District)

- 2.5.9 To support an active pedestrian environment, buildings along US Hwy. 50 should provide covered overhead protection in the form of recessed arcades or protruding canopies. Public entrances to buildings shall ensure protection from unloading roof snow.



Image 16. Locate outdoor pedestrian areas where solar exposure will maximize the opportunity for a comfortable year-round experience.



Image 17. Protruding overhead canopies create interesting architectural façades and provide protection from falling snow.



Image 18. Promote alternative transportation modes by incorporating facilities such as transit stops into the site design.

2.6 Bicycle Access

- 2.6.1 When required by the Development Code and Design Manual, bicycle racks shall be installed close to building entrance(s). Within multi-building projects, the racks shall be placed so that they are convenient to all building/entrances.
- 2.6.2 Bicycle racks shall be aesthetically treated. Such treatments can include inverted “U” shaped bollards, metal piping ribbons, planter, etc. All racks shall be permanently affixed and not obtrusive to pedestrian and vehicular circulation.
- 2.6.3 Bicycle linkages to any adjacent bikeways and/or routes shall be provided.

STANDARDS AND GUIDELINES FOR THE TOWN CENTER AND HIGH-DENSITY TOURIST DISTRICTS

(In addition to those identified previously, the following standards and guidelines apply to properties within Town Centers)

- 2.6.4 Site designs shall integrate multimodal transportation improvements (pedestrian, bicycle and transit facilities) consistent with the TRPA/TMPO Regional Transportation Plan, Mobility 2035.



2.7 Open Space Areas

- 2.7.1 High intensity open spaces, such as playgrounds and picnic areas, that generally generate noise levels above the normal levels associated with the surrounding neighborhood, should be located so that they are not directly adjacent to noise sensitive uses such as adjoining residences.
- 2.7.2 Low intensity open spaces, such as greenways and pedestrian paths, should be located around the perimeter of the site. This can serve as a buffer to the adjacent properties, particularly residential, as well as assist a project in meeting the required on-site landscaping.
- 2.7.3 Whenever possible, open space areas should be located on the south and/or west sides of the building and site. This allows the areas to receive maximum sunlight which accelerates melting of snow and ice. Deciduous trees are to be used to provide shade in summer months.
- 2.7.4 The location of the open space areas should give consideration to the wind exposure. If necessary appropriate screening features such as walls, landscaping, trellises, etc. should be incorporated into the project design.



Image 19,20. Bicycle trail connections in combination with bike-friendly amenities will help encourage alternative modes of transportation.

STANDARDS AND GUIDELINES FOR THE TOWN CENTER AND HIGH- DENSITY TOURIST DISTRICTS

(In addition to those identified previously, the following standards and guidelines apply to properties within Town Centers)

- 2.7.5 Site plans shall include strategies for protecting undisturbed sensitive lands and, where feasible, establish park or open space corridors connecting undisturbed sensitive areas within Centers to undisturbed areas outside of Centers.

2.8 Snow Storage

- 2.8.1 Each development shall incorporate snow melt and/or provide an area for snow storage . The snow storage area should be unobstructed by buildings so that the snow can receive direct sunlight to accelerate the snow melt.
- 2.8.2 Adequacy and location of snow storage shall be approved by Douglas County.

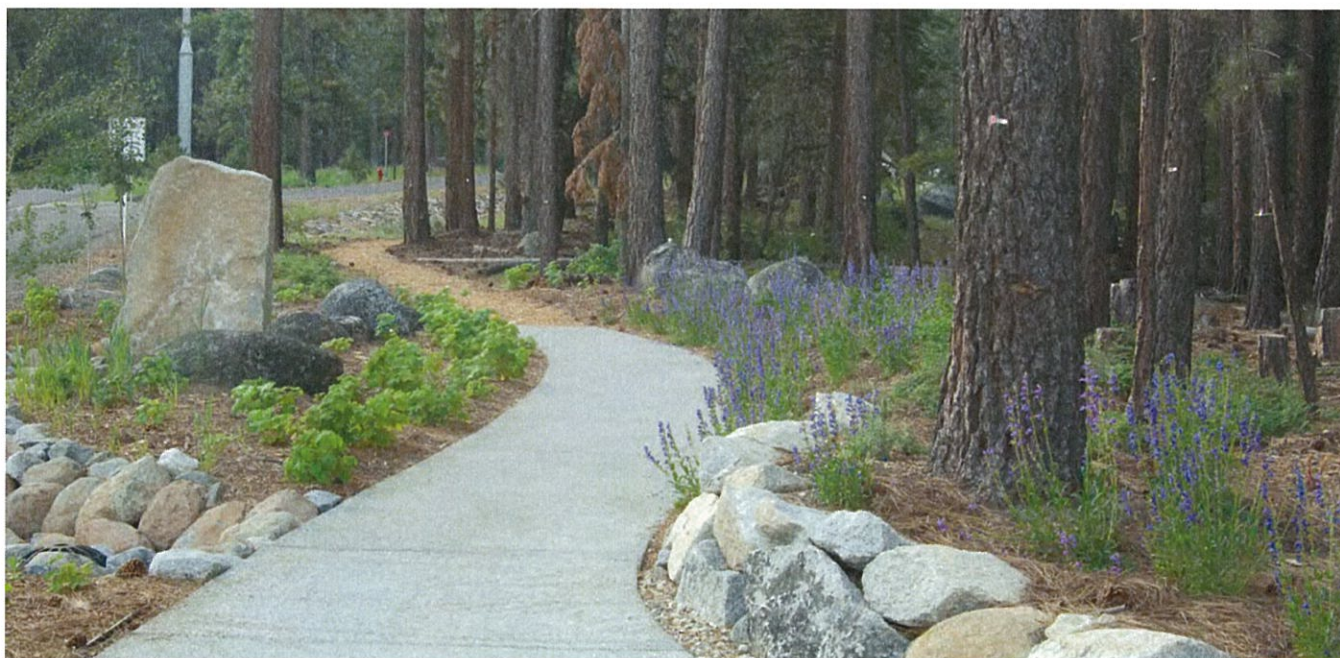

Image 21. To reinforce the recreation focus of the area, connections should be created to regional recreation attractions from major development nodes.

3. LANDSCAPE DESIGN

The landscape design standards and guidelines are intended to enhance and beautify pedestrian zones and to create a gradual transition from the more urbanized High Density Tourist District and Town Center District to the surrounding natural areas. The design of landscapes should respond to the intended site function with consideration of issues such as safety, maintenance and desired aesthetic quality. In areas focused on resort and retail activities, the landscape should create an inviting environment for pedestrians. This may be accomplished by establishing a rhythm of elements that unify the streetscape, providing plazas and event spaces that respond to a site’s environmental factors and by screening undesirable views or framing impressive vistas. In contrast, undeveloped areas and areas abutting natural landscapes should incorporate plant materials spaced in natural-looking groups to seamlessly transition into the natural environment.

3.1 General

- 3.1.1 Native vegetation should be utilized whenever possible, consistent with TRPA Landscape Standards and Fire Defensible Space Requirements (Table 5-2: Site Type Recommended Species List, TRPA BMP Handbook).
- 3.1.2 Vegetation shall be used to screen parking, alleviate long strips of parking space, and accommodate storm water runoff where feasible.
- 3.1.3 Vegetation should be used to give privacy, reduce glare and heat, deflect wind, muffle noise, prevent erosion, and soften the line of architecture.
- 3.1.4 Minimize grading and preserve existing vegetation whenever possible.
- 3.1.5 Landscape designs should respond to the seasonal environmental conditions to encourage outdoor spaces that are comfortable year-round.
- 3.1.6 Create a quality built environment with the inclusion of amenities such as street furnishing, plantings, art works, and water features to enhance the places that people will walk, gather, or recreate.
- 3.1.7 Landscapes shall be irrigated to establish planting and provide the correct water levels to support the long term growth of landscape. Irrigation systems must use efficient water methods, group planting into similar hydro-zones, and use moisture sensors to control the use of water.



Image 22. Plant material used for screening should be effective during both the summer and winter.

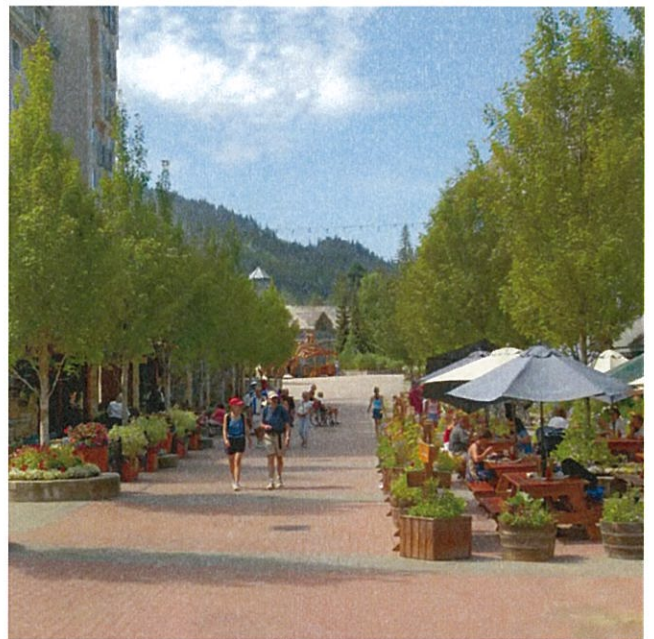

Image 23. Landscapes within developed areas may be formally arranged to reflect the built environment and create an inviting environment for pedestrians.

4. BUILDING DESIGN

The architectural design standards and guidelines establish a quality and character for the built environment that reflects the area’s mountain setting and environmental conditions. These standards are not intended to restrict imagination, innovation or variety in design, but rather are intended to highlight design principles that can result in creative solutions that enhance the quality and character of the built environment. Scenic and visual quality is not a question of style and therefore no specific architectural style or theme is proposed. The intent is to create design solutions that encourage a variety of architectural forms, scales, colors and materials that collectively fit within the natural mountain environment.

4.1 General

- 4.1.1 Buildings and additions to existing buildings are to be designed to complement rather than dominate their surroundings. They should be compatible with the surrounding buildings and should incorporate similar architectural elements or facades.
- 4.1.2 Buildings shall employ authentic, textured materials, compatible with the traditional and rustic resort style of the Lake Tahoe Region. Highly reflective materials are considered undesirable, because of their tendency to create uncomfortable glare conditions.
- 4.1.3 Building height shall be consistent with the Tahoe Area Plan Regulations (Chapter 20.703 of the Development Code).
- 4.1.4 Hotel, resort or institutional uses which propose a passenger loading and unloading area, a porte-cochere, or other similar feature should be provided and may be required. The design of an attached or detached port-cochere must contain the same architectural features and building materials as the primary building.
- 4.1.5 The use of standardized “corporate” architectural designs associated with chain or franchise buildings (prevalent with restaurants, service stations and retail stores) is strongly discouraged and alternative designs consistent with this design manual may be required.



Image 24,25. Authentic building materials such as stone and timber are consistent with the traditional resort vernacular, but they may also be incorporated into more contemporary designs that also fit within the natural mountain environment.

- 4.1.6 Predominate building colors shall be of earth tones, but may be accented with brighter colors. This will provide color variation, punctuation, and a sense of festivity appropriate to the resort destination.
- 4.1.7 Architectural designs should include functional and visual responses to climate considerations such as solar orientation with warm decks and view windows, protection from prevailing winds, sheltered entries and pedestrian areas, roof overhangs and thermal protections.
- 4.1.8 Buildings that exemplify “green building” design are desirable. This includes vegetated roofs, rainwater collection systems, designs that preserve existing trees and use of recycled, reclaimed or sustainably harvested materials.
- 4.1.9 Open spaces, walkways and alleys are encouraged to break up building mass, allow access through developments and create visual breaks.
- 4.1.10 Larger developments that group retail, hotel, multi-unit residential and/or office buildings are encouraged to shape distinct and memorable public spaces.
- 4.1.11 If a sign is intended, the building façade shall be designed to accommodate signage, so that tenants will have advertising without detracting from the appearance of the structure.

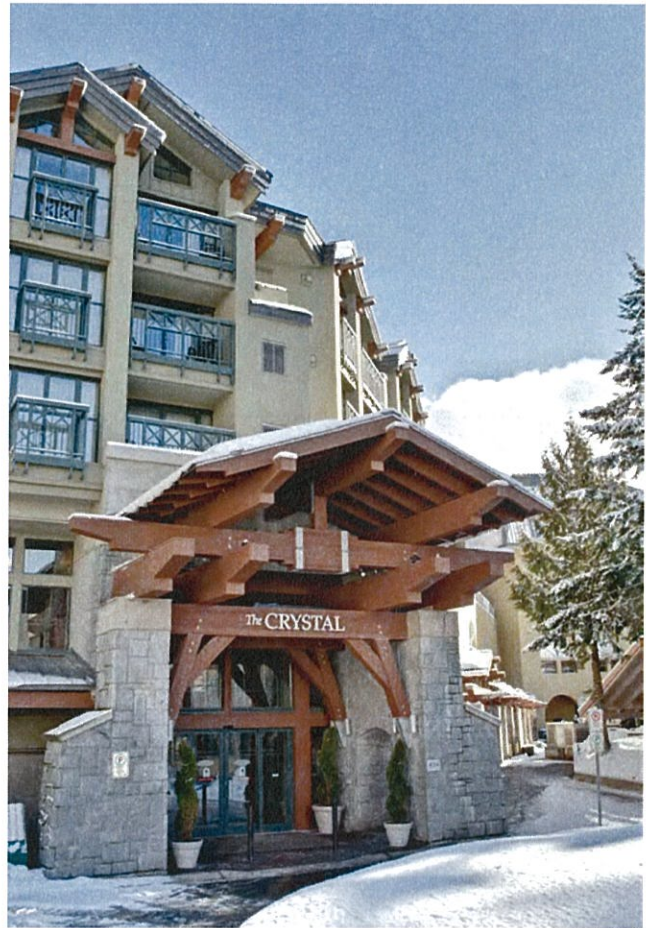

Image 26. Building entrances should be designed and located with consideration of climate considerations.



Image 27. Proper building placement and orientation, careful consideration of climate and interesting programmatic opportunities are all factors that lead to the creation of memorable public spaces.

STANDARDS AND GUIDELINES FOR HIGH-DENSITY TOURIST DISTRICT

(In addition to those identified previously, the following standards and guidelines apply to properties within the High-Density Tourist District)

- 4.1.12 The maximum allowable height will only be for towers associated with existing gaming properties and will be restricted to five towers. The proposed height will be applicable only if there is an existing high rise tower that is demolished and redeveloped. Redeveloped towers shall improve the visual quality of the area by replacing outdated and deteriorated facilities with newly constructed projects.
- 4.1.13 Up to four levels of occupied space will be allowed at the setback line from US Hwy. 50.
- 4.1.14 Redeveloped towers shall include design improvements such as strong pedestrian bases creating an orientation to the street, a mid-section with the potential to incorporate shadow lines and relief, articulation at the roof line aligned with the vernacular character of the region and building articulation to improve on the monolithic square shapes of the existing structures. These design features will have better proportions, comprise variety in design expression, and improve the appearance over the existing designs which do not demonstrate these characteristics.

4.2 Commercial, Institutional and Mixed-Use Building Elevations

Building exteriors are typically designed with clear distinction between the three main building components; the base, middle, and top. The base grounds the building to the site through the use of materials and forms that convey a sense of weight and stability. The base of a building is the also the most visually dynamic zone due to its connection to the street level. The middles of buildings should incorporate materials, textures, colors and detailing to provide interest and articulation. The tops of buildings are encouraged to be capped with well-proportioned, pitched roofs, acting as the uppermost unifying component.

- 4.2.1 Commercial, Institutional and Mixed-use buildings are to be designed on a “human scale” by using architectural enhancements. Such features should include windows, awnings, arcades, provide plazas and courtyards, and/or roof overhangs.
- 4.2.2 Commercial, Institutional and Mixed-use buildings of “box like” appearance are prohibited. The exterior walls shall be varied in depth and/or direction.

- 4.2.3 Varying portions of a building façade, particularly blank walls without windows or varying building materials, shall be articulated by the use of color, arrangement of façade elements, and/or change in material. These elements/materials shall include but are not limited to false windows, awnings, parapet eaves, trellises, arcades, siding, stone, or brick.
- 4.2.4 Awnings, parapet eaves or other similar decorative features shall provide a minimum vertical clearance of 8-feet.
- 4.2.5 Commercial, Institutional and Mixed-use metal buildings are not acceptable.

STANDARDS AND GUIDELINES FOR TOWN CENTER DISTRICT

(In addition to those identified previously, the following standards and guidelines apply to properties within Town Centers)

- 4.2.6 Building design shall be coordinated on all elevations in regards to color, material, form and detailing in order to achieve design harmony and integrity. Parapet walls should be treated as part of the building design, not as unrelated visual elements. Elevations need not look alike for a sense of overall architectural continuity to be present.



Image 28. Varying wall planes reduces the visual scale of a structure and helps to highlight interesting building features.



Image 29. Buildings within a development should not all look alike, but rather they should be visual balanced through their use of color, materials, form and detailing.

- 4.2.7 Development within the Town Center District shall incorporate buildings with varied heights and densities.
- 4.2.8 Properties along US Highway 50 with ground level retail and commercial uses shall provide primary pedestrian access directly to the street, in order to ensure an enjoyable and interesting visual experience for pedestrians. Long expanses of inactive building frontage shall be avoided by utilizing architectural elements such as transparent window surfaces, arcades, internal building uses that flow outdoors, and frequent building entry points.

Replacement of contrasting colors, monotonous wall surfaces, and the outdated design will also be design improvements over the existing conditions.

- 4.2.10 Dominate blank building walls shall be replaced with an open and more transparent building façade. Shops and restaurants oriented to the street will help establish a lively pedestrian promenade.

STANDARDS AND GUIDELINES FOR HIGH-DENSITY TOURIST DISTRICT

(In addition to those identified previously, the following standards and guidelines apply to properties within the High-Density Tourist District)

- 4.2.9 The scoring of vividness, intactness, unity and variety shall be improved with new building elevations and better design in the built environment. The existing conditions have an appearance characterized by repetitive wall surfaces, clutter in the foreground and disassociated design. Redeveloped towers will create opportunities to generate visual interest, articulate the space, and create entries.



Image 30. As part of a tower redevelopment project, new lower scale buildings will be organized along US Hwy 50 to create more visual interest through variations in building scale and density.

4.3 Industrial Building Elevations

- 4.3.1 Industrial buildings shall be articulated by the use of varying colors, materials and textures. Features such as windows, decorative/false windows, recessed windows, building projections or recesses, and entryway treatments are to be incorporated in the building elevation(s) which face a parking lot or street.
- 4.3.2 Industrial metal buildings are permitted provided that any façade, visible from a street, is improved to include at least one of the following, but not limited to: wood or vinyl siding, stucco, brick or stone treatment. Windows shall have a minimum 4 inch trim or decorative window shutters.

4.4 Roofs

Building caps or roofs offer a design distinction that will allow the mountain setting to be incorporated into a building's design. A definitive "building top" that steps, slopes or otherwise breaks the rectangular form will prevent blocky structures from being built.

- 4.4.1 Roofs for buildings other than towers, must have at least one of the following features around the entire building: 1) stepping parapet roofs concealing flat roofs, 2) overhanging eaves, and/or 3) sloped roof. Up to 25% of roof surface may be flat.
- 4.4.2 For buildings other than towers, height of the building should be varied so that distinctive roof lines are created.
- 4.4.3 All roof-top equipment including, but not limited to, satellite receiving dishes, communication equipment and HVAC units shall be screened from view.
- 4.4.4 Reflective, untreated metal roofs are prohibited. All exposed metal surfaces shall be painted in a flat, non-glossy paint to complement or match the color of the exterior roof building material.

4.5 Multiple Tenant Buildings

- 4.5.1 Multi-Building/Tenant developments shall have consistent color schemes and wall textures, roofs, roof slopes, awning, arcades and other similar architectural features.
- 4.5.2 Smaller retail stores that are part of a multi-tenant commercial building shall have display windows and separate entrances. The principal building must have a clearly defined, visible customer entrance features such as but not limited to canopies, arcades, arches, wing walls and planters.



Image 31. Distinctive roof lines are created with roof forms and building heights that vary.



Image 32. Multiple tenant buildings shall have display windows with separate entrances.

5. SIGNS

The sign design standards and guidelines establish the parameters for developing high quality signs that will contribute to the overall identity of a district and help pedestrians and drivers locate businesses and services. Signs should be limited to specific locations where information is needed to direct visitors to key destinations or to communicate regulations for public safety or protection of natural resources. To accommodate the variety of roadway and pedestrian environments a mix of sign styles and their associated design standards are described below. The goal is to establish sign standards that recognize the commercial communication requirements of all sectors of the business community and to improve the visual quality, using signs that include natural materials in a manner that is consistent with the architectural style of the region.

5.1 General

- 5.1.1 Unless modified by these standards, all signs within the South Shore Area Plan and Tahoe Douglas Area Plan must meet the provisions of Section 20.703.180, Signage, of the Douglas County Development Code, as well as Chapter 38, Signs, in the TRPA Code of Ordinances.
- 5.1.2 Designs should be simple and easy to read with the number of lettering styles and amount of copy kept to a minimum, preferably giving only the name of the business.
- 5.1.3 Signs should be designed and located to be compatible with their surroundings in terms of size, shape, color, texture, and lighting. They should not compete visually with other signs.
- 5.1.4 Signs should be integrated into building and site design, and not appear as if added as an afterthought. They should be incorporated into the design of the façade, and should complement the architecture in terms of shape, placement, colors, and materials.
- 5.1.6 Reflective, fluorescent, and primary colors should be avoided.
- 5.1.7 When possible, signs should be consolidated into unified systems in order to avoid sign clutter along the street. Signage attached to the structure is encouraged.
- 5.1.8 Free standing signs should be kept low whenever site and visibility allow. Shrubs placed around base of a freestanding sign integrate it with the ground plane and screen any low level lights.
- 5.1.9 Illuminated signs should not be high intensity and glaring in nature. The larger the sign, the lower the level of illumination should be. Illumination of the letters is preferred over illumination of the sign background. It is most preferable the signs be externally illuminated. Light bulbs should not be exposed.



Image 33. Signs should convey unique and interesting aspects of a business through artful designs.



Image 34. Free standing signs shall be integrated with the ground plane through the use of plants and sign bases that anchor the sign to the site.

- 5.1.10 Signs should be located to respect pedestrian and driver safety. Projecting signs shall clear walkways by eight (8') feet and shall project no closer than two (2') feet from the curb line. Height allowances over driveways, alley and parking areas shall be a minimum of 13'6". Signs should be placed to avoid conflicts with door openings. Signs are not permitted in the road right-of-way. Banners across U.S. Hwy 50 are subject to review and approval by the Nevada Department of Transportation (NDOT).
- 5.1.11 Illuminated signs should be positioned so that the light does not shine directly on adjoining properties, cause glare, or shine in the eyes of motorists or pedestrians.
- 5.1.12 The back for any one sided regulatory, directional, or informational sign located in a Rural transition or Rural Scenic Highway Corridor should be painted or otherwise colored closely to match the color of the adjacent landscape.
- 5.1.13 Signs should have no more than 60% of the sign area in copy. Sign copy includes all letters, numbers, characters, symbols, and other graphics which are part of the sign. The guideline does not apply to signs which consist of individual letters, characters, or other symbols and which have no perimeter or border. Sign Area = X*Y Sign Copy=(A*B)+(C*D) Sign Copy=.60(X*Y).

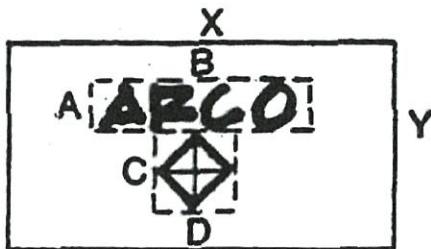

Image 35. Sign area measurement diagram.

5.2 Multiple Tenant Buildings

- 5.2.1 Every new or redevelopment project with three or more tenants requires a master sign plan. Sign placement, scale, and readability are to be considered in the design.
- 5.2.2 In multi-building / tenant complexes with three or more tenants all signs shall have a consistent theme through the use of compatible colors, materials, shapes, sizes and types of signs. A master sign plan standardizing the signs shall be provided as part of the development proposal.

5.3 Wall Signs

- 5.3.1 Wall signs must be integrated into the building and site design and not appear to be added as an afterthought.



Image 36. Incorporate wall signs into the design of structures to prevent the appearance that signage was added as an afterthought.

5.4 Monument Signs

- 5.4.1 Monument signs shall be designed so that they complement the architecture of the building/complex. The design of the monument should not be the main focus of the site, but rather blend in with the site and should contain only the name of the center/business, or major anchor.
- 5.4.2 Monument signs shall be located so that they do not create blind corners, interfere with circulation, parking or traffic safety.
- 5.4.3 Monument signs shall include the street number for the site. Street numbers shall be clearly visible from the street frontage during day and night.
- 5.4.4 Monument signs should be at eye level of passing motorists.
- 5.4.5 Two monument signs (or freestanding signs per Section 38.8.2. of the TRPA Code of Ordinances) may be allowed for the commercial complex located on APNs:1318-23-4-038, -039, -040, and -041, as long as two signs do not create a traffic safety hazard and the transfer of land to complete the Burke Creek Restoration Project is complete.

5.5 Points of Interest (Wayfinding) and Community Entry Sign

- 5.5.1 A point of interest (wayfinding) signage program should be developed by the Tahoe Chamber of Commerce, in coordination with Douglas County and NDOT, to promote walking and biking to recreation destinations.
- 5.5.2 One community entry sign shall be located near Kahle Drive and Highway 50, at the entry to the South Shore.



Image 37. Monument signs should be utilized to consolidate the major building tenants as part of a single coordinated sign.

6. LIGHTING

The lighting design standards and guidelines encompass the range of lighting that is necessary to provide safety and security as well as provide, in limited areas, the ambient lighting that will allow for a festive atmosphere enhancing the qualities of an active civic place.

6.1 General

- 6.1.1 Lighting should be used to provide illumination for the security and safety of on-site areas such as parking, loading/unloading, pedestrian pathways and working areas. Excessive use of lighting fixtures is prohibited.
- 6.1.2 Fixture style and location must be compatible with the building's architecture, site design and landscape design. Decorative fixtures are highly recommended and where warranted, may be required. Light fixture style is to be consistent throughout the project.
- 6.1.3 Light fixtures shall be located facing away from adjacent sites (particularly residential parcels) so that the light does not spill-over onto abutting properties. Parking and building light fixtures must be cut-off luminaries that have less than 90-degree cut-off so that the light is not emitted horizontally or upward.
- 6.1.4 Projects located near residential or open space areas shall use low intensity / wattage lights and all lighting is to be extinguished or reduced in intensity 30 minutes after the close of business.
- 6.1.5 Wall pack, flood and other light fixtures which illuminate upwards or horizontally are prohibited.
- 6.1.6 A site photometric plan denoting candle illumination on a specific grid, both within the project and off-site, may be required where the project is located adjacent to residential uses and site lighting design indicates a potential for nuisance light impacts to the abutting property.
- 6.1.7 The overall height of parking lot light fixtures shall be not more than 15-feet in or within 100-feet of residential districts and not more than 26-feet (per TRPA code) within non-residential districts. Pedestrian walkway lights shall be of appropriate scale and are encourage to be low intensity bollard type fixtures with a maximum height of 10-feet.
- 6.1.8 Off-site street lighting may be required over driveways to provide safe entrances and exits.



Image 38. Fixtures with fully shielded light sources and 90 degree cutoffs protect the night sky by directing light downward.

- 6.1.9 Exterior lighting should be minimized to protect dark sky views, yet adequate to provide for public safety, and should be consistent with the architectural design.
- 6.1.10 Exterior lighting shall utilize cutoff shields that extend below the lighting element to minimize light pollution and stray light.
- 6.1.11 Lights shall not blink, flash, or change intensity except for temporary public safety signs.
- 6.1.12 The level of illumination shall be set at the minimum level required for use and even distribution of the light. This will prevent wide contrast levels between light sources and prevent uneven light dispersion. Refer to the following types of lighting and their associated illumination levels.
 - a. *Street lighting is intended to address safety concerns along primary and secondary streets for vehicular and pedestrian transportation needs. Levels of illumination for street lighting shall not exceed 3.0 foot candles, measured within one foot of the base at ground level.*
 - b. *Pedestrian zone lighting is intended for those areas where pedestrians are encouraged to gather such as outdoor plazas, outdoor dining areas, building entries, and pedestrian*

thoroughfares. Levels of illumination shall not exceed 5.0 foot candles in pedestrian spaces.

- c. *Safety and security lighting is intended for secondary pedestrian areas or landscape zones that require illumination for security and pedestrian safety. Levels of illumination shall not exceed 2.5 foot candles, measured within one foot of the base at ground level.*

- 6.1.13 Landscape lighting is allowed to highlight elements of the landscape through the use of down lighting with concealed fixtures or fixtures with lens hoods to screen the light source. Landscape lighting fixtures shall be painted with dark colors including brown, gray, black or green.
- 6.1.14 The entire lighting assembly (pole and fixture) shall be constructed with timber or painted a dark color such as brown, gray, black or green.
- 6.1.15 Lighting shall be limited to Incandescent, High Pressure Sodium, Metal Halide, Compact Florescent, or LED type lighting in all applications for exterior use.



Image 39. Lighting levels should be designed to provide an even distribution of light to prevent contrasting lighting levels within areas intended to support similar functions.

STANDARDS AND GUIDELINES FOR THE TOWN CENTER AND HIGH- DENSITY TOURIST DISTRICTS

(In addition to those identified previously, the following standards and guidelines apply to properties within Town Centers)

- 6.1.16 Lighting which directs light downward shall be used in all applications except for the applications described in the Accent Lighting Standards.
- 6.1.17 Accent Lighting may be included as part of a lighting plan to prevent dark, uninviting, and oppressive building surfaces above the first floor. Illumination shall be for selective architectural features that serve to landmark, or otherwise highlight design features. Specifically, lighting of distinguished architectural features such as entries, arcades, chimneys, cornices, balconies, exterior trusses, highly textured material, knee braces, enriched architectural facades or landmark features are permitted. Wall lighting of blank wall or repetitive wall facades shall not be permitted. Up to 35% of vertical architectural surfaces may have accent lighting. This may include low angle or upward lighting.

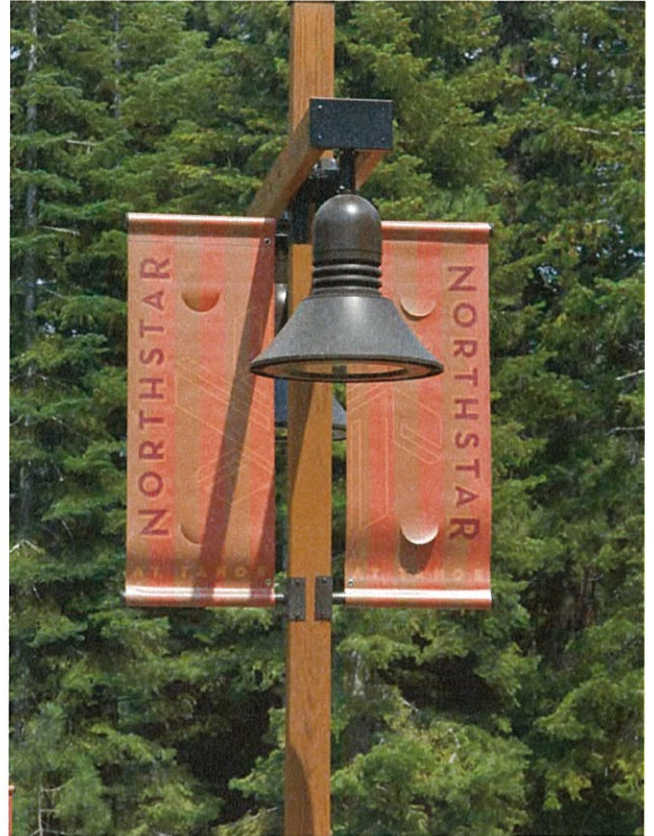

Image 40. Custom light poles consistent with the overall architectural style are encouraged.

7. SCREENING

The architectural design of a project shall include elements that screen from public view all external mechanical equipment, including refuse enclosures, electrical transformer pads and vaults, satellite receiving disks, communication equipment, and utility hardware on roofs, buildings, or the ground.

7.1 General

- 7.1.1 Any outdoor mechanical equipment such as transformers, HVAC units, electrical boxes, back flow preventers, etc. located on the ground should not be visible from the street or the main drive aisle. To the extent possible, use of subterranean vaults is recommended. In any event, such structures shall be screened from view. The method of screening shall be integrated with the adjacent structure in terms of landscaping, wall material/color, shape and size.
- 7.1.2 All roof-top equipment shall be screened from view as identified with the architectural guidelines of this manual.
- 7.1.3 Storage areas accessory to the permitted use(s) and visible from the public right-of-way, shall be screened from view by the use of a concrete block wall or similar opaque structure. Storage

areas not visible from the public right-of-way may be screened by the use of chain-link fence with metal or plastic slating.

- 7.1.4 Trash enclosures shall be constructed of masonry block consistent in color and texture with the primary building. Steel grates shall be hung from individual steel posts imbedded in concrete. Trash enclosures visible from a street shall be screened with landscaping including, but not limited to evergreen trees or columnar shrubs. The following dumpster design criteria is provided from the Douglas County Design Criteria and Improvement Standards, Part 1, Appendix A.

1. *Typical construction materials:*
 - A. *Masonry block or poured concrete*
2. *Gates are required for installations:*
 - A. *Gate shall be mounted on metal posts imbedded in concrete at corners, not attached to corners.*

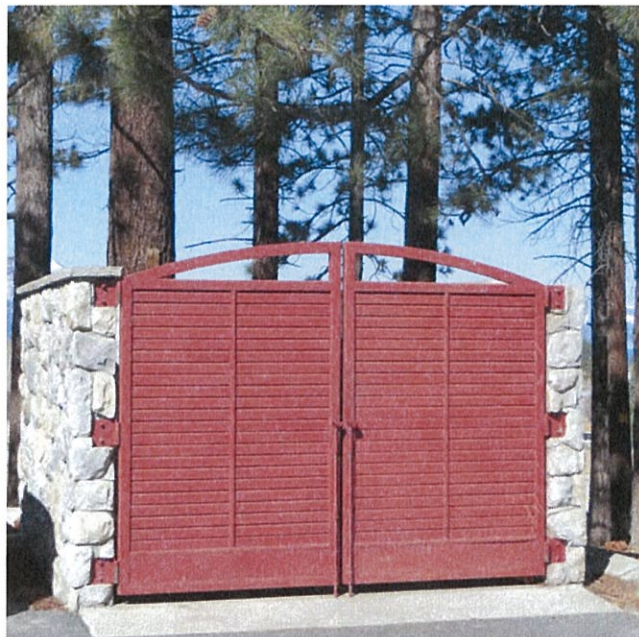

Image 41. Dumpster enclosures designed using materials and finishes consistent with the primary building helps to protect visual quality by unifying the appearance of site structures.

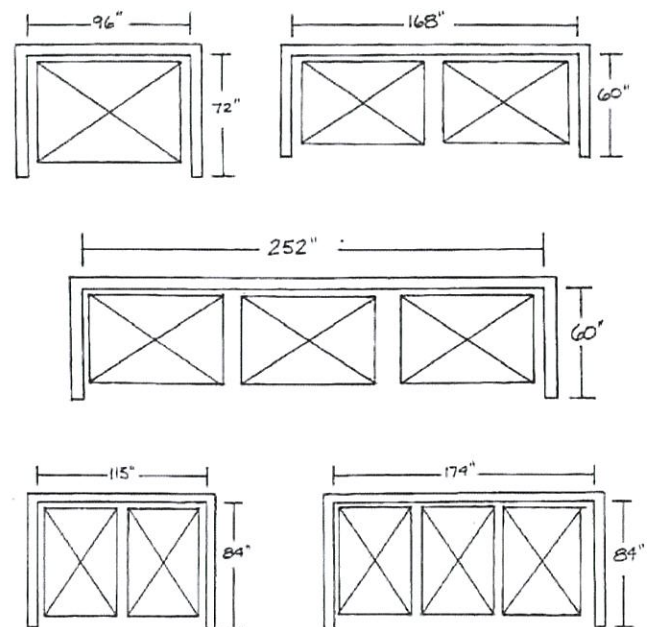

Image 42. 1 1/2 and 2 yard dumpster enclosure diagrams.

- B. Metal framed with chainlink or colored slats.
 - C. Gate shall open 170 degrees minimum.
 - D. Gate shall lock in either the open or closed position.
3. Surface - Concrete, level:
 - A. Concrete minimum thickness of 4 inches on 4 inches of aggregate base.
 - B. Surrounding paved area level with enclosure.
 4. Stops to prevent dumpster from hitting walls when moving in and out shall be provided.
 5. Slope from the front of the trash enclosure shall be a minimum of 2% and a maximum of 4%.
 6. Enclosure height shall be 72".
 7. Any required drainage shall not interfere with movement of the dumpster.
 8. Clear access equal to the size of the enclosure, but not less than 8ft. by 10ft. must be maintained in front of the enclosure at all times.

9. Enclosures are for the express use of containing dumpsters, no other uses are permitted.

7.1.5 Accessory structures which are used for screening/storage purposes shall be architecturally compatible with the primary building(s).

7.2 Walls and Fences

7.2.1 Chain-link fencing with metal, wood or plastic slats are not permitted within the front yards.

7.2.2 Walls must be designed to blend in and be compatible with the building color and material. Landscaping, including vines, should be planted to soften the wall elevation and limit graffiti to the extent feasible.

7.2.3 Long wall surfaces must offset and be designed to prevent monotony. Wall and fence design must be consistent with Title 20. Walls and fences not used for screening of storage areas shall provide pedestrian opening if adjacent to sidewalks.

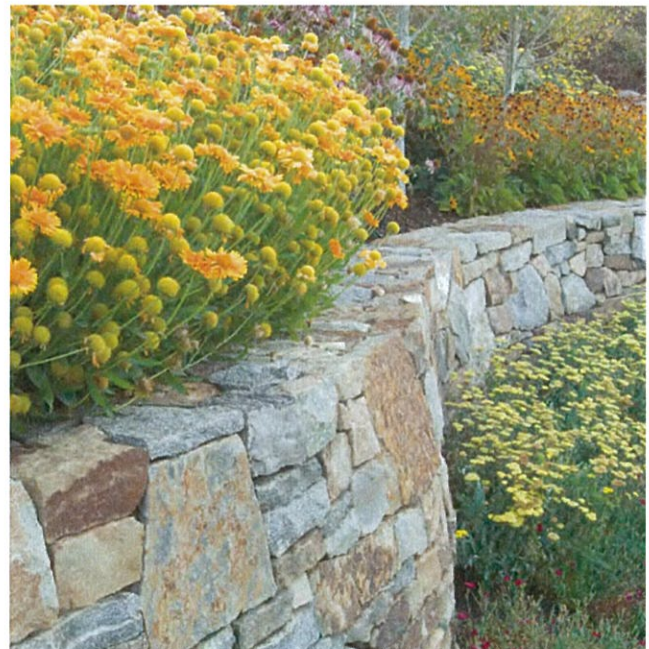
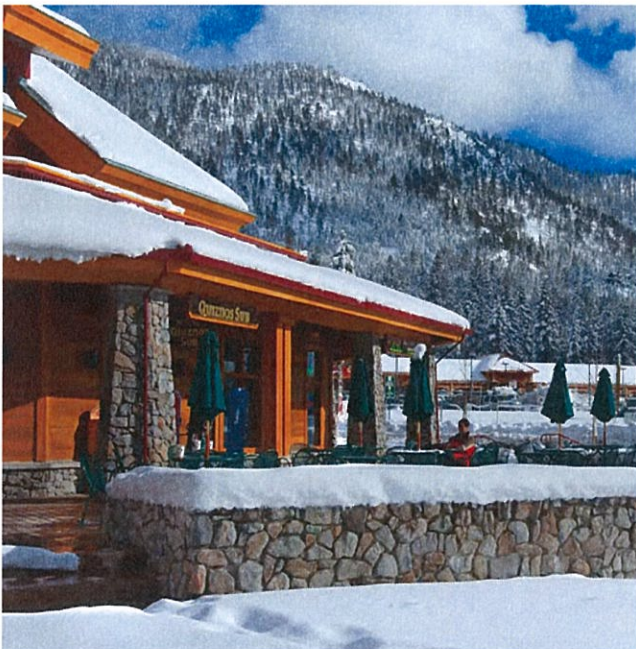

Image 43, 44. Walls shall be designed to blend in and complement building materials and colors. Curving wall layouts and incorporating landscape materials will help soften the contrast of the wall's vertical face.

Appendix A: Comparison of Douglas County Design Criteria and Improvement Standards (DCDCIS) to the Tahoe Area Design Standards and Guidelines

Does the DCDCIS standard apply to the Tahoe Area? Replacement standard if DCDCIS standard does not apply to the Tahoe Area.

2. SITE LAYOUT		
2.1 Building Arrangement and Location (DCIS Standards)		
2.1.1	Commercial and institutional building shall be oriented with the primary entry and façade toward the street or the primary drive aisle.	NO Mixed-Use buildings shall be oriented with the primary entry and façade toward the street or the primary drive aisle.
2.1.2	In multi-building commercial and private recreational developments, the buildings shall be clustered creating pedestrian shopping plazas, corridors and open spaces. Where clustering is impractical, a visual link between the buildings shall be incorporated. This link can be accomplished by the use of an arcade system, trellises or other similar open structures.	YES
2.1.3	Buildings shall be located in a manner that will complement adjacent structures and properties. Sites should be developed in a coordinated manner to provide order and diversity, and avoid and “unplanned” development look.	YES
2.1.4	Loading areas or docks shall be located to the rear or the side of the building, away from public rights-of-way, and cannot interfere with the on-site circulation. The loading areas/docks shall be designed so their visibility is minimal by using features such as wing walls and landscaping. The location and orientation of the building must consider accessibility to the loading areas.	NO Loading areas or docks shall be located to the rear or the side of the building, away from public rights-of-way, and cannot interfere with the on-site circulation. All loading and unloading shall take place on site. Street servicing is discouraged. The loading areas/docks shall be designed so their visibility is minimal by using features such as wing walls and landscaping. The location and orientation of the building must consider accessibility to the loading areas.
2.1.5	Automotive repair/service building or other uses which provide mechanical services should be arranged so that the bay entries/exits are not fronting a primary street. Fast food restaurants should be oriented so that the drive-thru window façade does not front the primary street.	NO Automotive repair/service buildings or other uses which provide mechanical services should be arranged so that the bay entries/exits are not fronting a primary street.
2.1.6	The existing natural features on a site such as trees, slopes and rock outcroppings should be retained and incorporated into the site layout to create more interesting and unique designs that are integrated with the natural existing environment.	YES
2.1.7	The building location and orientation must consider sun and wind exposures, minimizing noise levels and impacts to safety and privacy. Pedestrian plazas, open space areas, and walkways should be located on the south or the west sides of the building(s) so that maximum sun exposure is provided during winter months. Deciduous trees can be used to effectively provide shade in the summer months. Buildings should be located so that screening from wind is provided. Typical wind direction in the Tahoe Basin is primarily from the west, northwest and southwest.	NO Buildings shall be designed and sited with consideration of solar exposure, climate, noise, safety, fire protection and privacy. Outdoor spaces shall be designed to create interesting gathering spaces with opportunities for year-round event programming.
2.1.8	Building setbacks shall be consistent with the provisions of the Douglas County Consolidated Development Code. Consideration should be given to any future expansion by providing adequate area to meet development code requirements and compliance with the guidelines set forth by this manual.	NO Setbacks shall be consistent with the Tahoe Area Plan Regulations (Chapter 20.703 in the Douglas County Development Code).
2.1.9	Detached storage building and storage areas shall be located in the rear of the site. The storage areas and materials shall be properly screened by the use of fences (chain link fences must be slatted), landscaping, decorative walls or other similar opaque screening fixtures.	NO Detached storage buildings, service yards, maintenance yards, warehousing and outdoor storage areas shall be located in areas that are not highly visible from major transportation corridors, scenic turnouts, public recreation areas, or the waters of Lake Tahoe.

2.1.10	Buildings must be arranged or designed so that they do not create a "blind corner" and/or impair visibility. Specific consideration and design alternatives must be evaluated for corner lots and instances where there are existing and adjoining driveways.	YES	
--------	---------------------------------------------------------------------------------------------------------------------------------------------------------------------------------------------------------------------------------------------------------------	-----	--

New Tahoe Area Guidelines and Standards (Building Arrangement)

2.1.11	<p>a. Site plans are encouraged to incorporate Low Impact Development techniques to reduce the impact of built areas and promote naturally functioning systems. The following practices may be integrated with the overall design of landscape areas to combine the functions of stormwater treatment with aesthetically pleasing landscape features:</p> <ol style="list-style-type: none"> 1. Pervious pavement materials that allow water to pass through the paving and infiltrate into the ground are encouraged for pedestrian applications. Other pavement surfaces may incorporate pervious pavements but shall be designed in conjunction with the site's BMPs. Pervious pavements are defined as materials with 10% voids that allow the pavement to create no surface run-off in combination with a water collection zone under the paving. 2. Preserving existing trees should be planned for with efforts on preserving large groups of forest rather than individual trees that are subjected to changes of runoff, grades, or surface coverage. The protection zone for trees extends to the drip-line of the tree's canopy. 3. As part of surface water management, small areas of infiltration catchments are to be incorporated into the final contour of the landscape. These features will offer the reduction in run-off from each site. 		
2.1.12	Building design and placement should preserve and enhance views from public areas towards Lake Tahoe and mountain ridgelines.		
2.1.13	Building design and placement shall promote a visual balance between the various elements both on and adjacent to the site. Building arrangements shall neither create monotonous or overpowering forms nor should they dominate the visual composition.		
2.1.14	New buildings adjacent to existing lower scale residential development shall respect the scale and privacy of adjacent properties by varying the massing within a project and incorporating architecture designs and building treatments that transition to smaller scale buildings.		
2.1.15	Properties along US Highway 50 with ground level retail and commercial uses shall provide primary pedestrian access directly to the street. The intent of this retail/pedestrian street requirement is to present a dynamic, fragmented street front to outdoor spaces, rather than uniform blocks of building mass.		
2.1.16	Buildings that are 8 stories or higher, should be sited so their longest frontages are perpendicular to the primary street. Lower buildings located on the primary street frontage are encouraged to address the street so that their longest frontage is parallel to the street edge.		
2.1.17	The travel route of Hwy 50 has a "canyon effect" because the existing tower structures are located too close together with inadequate setbacks. Within a given property, 80% of the buildings fronting Hwy 50 shall not exceed 56 feet in height when an existing building or buildings are being replaced within 100 feet of the right-of-way. 20% of the building or buildings frontage may be constructed to a maximum height of 95 feet. Redeveloped towers up to the maximum allowable height shall be sited behind buildings fronting on Hwy 50. Lower buildings at the street level will reduce the visual dominance of the towers and improve the visual condition along the Highway 50 travel route by creating a pedestrian scale street section by shifting the tower height away from the immediate area of the street. Existing buildings with non-conforming height are allowed to do frontage improvements up to their existing height.		
2.1.18	Redevelopment of the existing towers is contingent on the creation of new and additional open space that will replace a portion of the surface parking with a landscape setting. Additional open space would improve the travel route rating with the development of a visually attractive landscape.		

TRPA Related Building Arrangement and Location Design Standards (Ref. Only)

<p>a. Existing natural features outside of the building site shall be retained and incorporated into the site design to the greatest extent feasible. Projects shall be designed to avoid disturbance to rock outcrops and stream environment zones and to minimize vegetation removal and maintain the natural slope of the project site and be consistent with Section 36.12 (TRPA-Ch.36.5.1, A).</p>			
<p>b. Projects shall be designed to use existing disturbed areas rather than undisturbed areas for the siting of all improvements except when (TRPA-Ch.36.5.1, B):</p> <ol style="list-style-type: none"> 1. The disturbed area is precluded from development by setbacks or other such limitations; 2. The disturbed lands are classified as sensitive lands and alternative sites classified as non-sensitive lands exist on the parcel; 3. The use of the disturbed lands would require more total disturbance than use of undisturbed lands; 4. Avoidance of other development impacts are of more importance than the preservation of undisturbed areas; and/or 5. The degree of existing disturbance is minor and the area shall be restored as part of the project. 			

2.2 Circulation and Parking (DCIS)

2.2.1	The on-site circulation must be logical and provide convenient, safe and direct flow of pedestrians and vehicles.	YES	
2.2.2	All parking areas, driveways, parking aisles and sidewalks shall be graded, drained and paved in accordance with the Development Code and Part II of the Douglas County Design Criteria and Improvement Standards.	YES	

2.2.3	Parking lots serving commercial and institutional projects which accommodate more than 25 spaces shall be divided into a series of connected smaller lots. Providing landscaping which offsets portions of the parking lot or locating parking areas on more than one side of a building are effective means by which visual impacts of large parking lots can be mitigated.	NO	New surface parking areas are discouraged within view of US Highway 50. New parking areas should be situated behind buildings and screened from street views.
2.2.4	Parking aisles shall be arranged to direct pedestrians parallel to moving cars thereby minimizing the need for pedestrians to cross parking aisles and landscape areas. As an alternative, separated pedestrian walkways should be incorporated in the parking lot design.	YES	
2.2.5	Whenever parking areas/drive aisles are connected to adjacent sites, the circulation must provide for similar direction of travel (both vehicular and pedestrian) and parking stalls to reduce conflict at points of connection.	YES	
2.2.6	In large development/shopping centers located along streets with high volume of vehicular traffic, frontage/local road and shared access are recommended and may be required.	NO	To promote efficient and safe vehicular and pedestrian circulation, curb cuts and private driveways shall be kept to a minimum.
2.2.7	In cases where one-way traffic aisles are provided, one-way traffic signs shall be clearly posted and one-way arrows shall be painted and maintained within the drive aisle.	YES	
2.2.8	The turning radii for drive aisles and loading areas shall meet the AASHTO standards for turning movements.	YES	
2.2.9	Parking spaces abutting structures must be separated by a 6 foot wide sidewalk or landscape planter.	YES	
2.2.10	Parking stalls shall be located so that vehicles do not back-up into primary ingress driveways. The first parking stall parallel to a driveway shall be separated by a landscape planter a minimum of 20 feet in width, one car length.	YES	
2.2.11	Loading/unloading areas shall be clearly identified by installing no parking signs and/or striping of the space. The areas must be located in the rear or the sides of the building and shielded so that they are not visible from the street. The size and number of the loading/unloading areas must be consistent with the requirement of the Development Code.	YES	
2.2.12	Parking areas abutting properties residentially used or designated shall be separated by a landscape planter a minimum of 10-feet in width and a 6-foot high masonry wall.	NO	Parking areas abutting properties residentially used or designated shall be separated by a landscape buffer a minimum of 10 feet in width. In addition to landscaping, perimeter earth bearing is recommended as an effective way to reduce the visual impact of surface parking lots.
2.2.13	All parking and drive aisles shall be designed to provide sufficient emergency vehicle access and maneuverability.	YES	
2.2.14	All parking shall comply with the most current American with Disabilities Act (ADA) standards and regulations.	YES	
2.2.15	Establishments that typically require or generate frequent passenger loading and unloading shall provide specifically designated loading/unloading stopping bays. Direct ingress and egress should be provided so that vehicles are not directed into the on-site drive aisles.	YES	
New Tahoe Area Guidelines and Standards (Parking and Circulation)			
2.2.16	The number of required parking and loading spaces shall be consistent with the Tahoe Area Plan Regulations (Chapter 20.703, Parking and Loading).		
2.2.17	Parking lots shall be located and designed with BMPs to capture, treat and infiltrate storm water.		

TRPA Related Parking and Circulation Design Standards (Ref. Only)

a. Onsite parking areas shall be provided with landscaped perimeters. On-site parking areas greater than one-quarter acre in size shall be provided with landscaped islands designed in accordance with the following: (TRPA-Ch.36.5.2, A).
 1. Landscaped islands should also be provided within the interior of parking areas to break up expanses of pavement and screen parked vehicles. Parking areas should be divided into bays not exceeding 75 feet in length with landscaped buffer strips between bays. Tree planting on the interior of the parking area should be provided at an average ratio of at least one tree per four (4) spaces.

2.3 Parking Structures (DCIS)

2.3.1	The exterior surface materials of the parking structure must be compatible and complementary to the main structure.	YES	
2.3.2	The exterior façade must be articulated by the use of complementary colors, stepping of floors, arrangement of façade elements and/or alternative building materials is highly desirable.	NO	The exterior façade facing a public right-of-way must be articulated by the use of one or more of the following features; complimentary colors, stepping of floors, arrangement of façade elements and/or alternative building materials.
2.3.3	Solid screening elements shall be provided on each floor of the parking structure to sufficiently screen parked vehicles. Ground floor screening elements shall include landscape planters.	NO	Solid screening elements shall be provided on a portion of each floor of the parking structure to sufficiently screen parked vehicles. Ground floor screening elements shall include landscape planters.
2.3.4	A minimum 5-foot wide landscape planter area shall be provided between the structure and a road, sidewalk or internal drive aisle. The planter shall include live plant material including but not limited to shrubs, trees, and vines.	YES	
2.3.5	The location of entrance and exit driveways shall be located/ designed so that the impacts to vehicular and pedestrian traffic are minimized to the extent possible. Exit driveways shall be designed so that "blind corners" are avoided.	YES	
2.3.6	Sidewalks must be provided along the full length of the building featuring customer entrances and along any façade facing public parking areas.	YES	

New Tahoe Area Guidelines and Standards (Parking Structures)

2.3.8 Locate new parking structures so they do not interfere with the opportunity to create a pedestrian oriented streetscape. Access to parking structures from US Hwy. 50 is allowed, but parking only structures fronting US Hwy. 50 are strongly discouraged.

2.4 Vehicular Access (DCIS)

2.4.1	Vehicular access points shall be kept to a minimum. However, the number and location of driveway curbs must be adequate to allow efficient traffic flow. Joint access between adjacent sites shall be utilized whenever possible to reduce traffic hazards and necessary curb cuts.	YES	
2.4.2	Driveways are to be designed and located to meet the AASHTO standards for turning movements.	YES	
2.4.3	The spacing between driveways and intersection corner clearance shall be consistent with the standards provided in Part II, Engineering Design and Criteria and Improvement Standards of the Douglas County Design Criteria and Improvement Standards.	NO	The distance between driveways and intersection corner clearance must be consistent with the standards provided in Part II, Engineering Design and Criteria and Improvement Standards of the Douglas County Design Criteria and Improvement Standards.
2.4.4	Commercial developments within the Towns of Minden and Gardnerville, and throughout the Carson Valley shall use interlocking pavers, stones or other similar treatments to denote driveway approaches to a minimum depth of 10 feet.	NO	Two-way traffic along Hwy 50 (or Main Street when Hwy 50 is realigned) is encouraged.

TRPA Related Vehicular Access Design Standards (Ref. Only)

a. New driveways shall be designed and located so as to cause the least adverse impacts on traffic, transportation, air quality, water quality, and safety (TRPA-Ch.34.3.2, A).
 b. Shared driveways are allowed if the effect is equal or superior to the effect of separate driveways (TRPA-Ch.34.3.2, B).
 c. Approved community plans may replace the standards in subsections 34.3.3 through 34.3.5, inclusive, with alternative specific provisions, provided such provisions are more appropriate to the situation and provide equal or superior measures to satisfy the environmental thresholds. See also subparagraph 12.6.3.C (TRPA-Ch.34.3.2, C).

d. On state and federal highways, the ingress/egress standards of the Nevada Department of Transportation shall apply, as appropriate, in addition to the standards in subsections 34.3.3 through 34.3.5, inclusive. Where the state standards conflict with subsections 34.3.3 through 34.3.5, inclusive, the state standards shall control (TRPA-Ch.34.3.2, D). d. On state and federal highways, the ingress/egress standards of the Nevada Department of Transportation shall apply, as appropriate, in addition to the standards in subsections 34.3.3 through 34.3.5, inclusive. Where the state standards conflict with subsections 34.3.3 through 34.3.5, inclusive, the state standards shall control (TRPA-Ch.34.3.2, D).
e. Slopes of driveways shall not exceed the standards of the Douglas County. Driveways shall not exceed ten percent slope, unless TRPA finds that construction of a driveway with a ten percent or less slope would require excessive excavation and that the runoff from a steeper driveway shall be infiltrated as required in Section 60.4. In no case shall the driveway exceed 15 percent slope (TRPA-Ch.34.3.2, E).
f. Driveways shall be managed in accordance with the Best Management Practices described in Section 60.4 of the TRPA Code of Ordinances (TRPA-Ch.34.3.2, F).
g. Adequate access shall be provided for emergency vehicles and for those persons attempting to render emergency services (TRPA-Ch.36.5.2,C).

2.5 Pedestrian Access (DCIS)

2.5.1	All sidewalks shall be constructed of Portland cement concrete or other similar concrete material.	YES	
2.5.2	Separate vehicular and pedestrian systems shall be provided. Pedestrian linkages between uses within development, surrounding developments and trails/bikeways shall be provided and emphasized, including distinct pedestrian access from parking areas to the building. Walkways should include enhanced paving, trellis structures or enhanced landscaping treatments. A continuous and direct sidewalk shall be provided from the street to the on-site sidewalk.	YES	
2.5.3	Sidewalks should be provided along the full length of the building featuring customer entrances and along any façade facing public parking areas.	YES	
2.5.4	On-site sidewalks must be a minimum of 4-feet wide. When parking stalls directly abut a sidewalk, the sidewalk shall be a minimum of 6-feet wide. If exterior stairways are used with the stairway landings on the sidewalk, the sidewalk shall be a minimum of 6-feet wide.	YES	
2.5.5	All pedestrian areas shall comply with the most current American with Disabilities Act (ADA) standards and regulations. Particular attention shall be given to ramps, accessible paths of travel, level landings and handrails.	YES	
2.5.6	Hotel, resort and institutional uses which have frequent loading and unloading of passengers are to provide a port-cochere or other similar feature at the passenger loading/unloading area.	YES	

New Tahoe Area Guidelines and Standards (Pedestrian Access)

2.5.7	Site designs and building arrangements shall promote pedestrian activity by providing enhanced design features along public roadways. Enhanced design features to be considered include increased setbacks, stepped heights, increased building articulation, and/or higher quality building materials.		
2.5.8	Promote alternative transportation modes such as walking, bicycling, transit use, and shared parking strategies which at a minimum shall include continuous sidewalks or other pedestrian paths and bicycle facilities along both sides of all highways with connections to other major activity centers.		
2.5.9	To support an active pedestrian environment, buildings along US Hwy. 50 should provide covered overhead protection in the form of recessed arcades or protruding canopies. Public entrances to buildings shall ensure protection from unloading roof snow.		

TRPA Related Pedestrian Access Design Standards (Ref. Only)

a. A pedestrian circulation system shall be incorporated into the site plan to assure that pedestrians can move safely and easily both on the site and between properties and activities within the neighborhood year round (TRPA-Ch.36.5.2, B).

2.6 Bicycle Access (DCIS)

2.6.1	When required by the development code, bicycle racks shall be installed close to building entrance(s). Within multi-building projects, the racks shall be placed so that they are convenient to all building/ entrances.	YES	
-------	--------------------------------------------------------------------------------------------------------------------------------------------------------------------------------------------------------------------------	-----	--

2.6.2	Bicycle racks shall be aesthetically treated. Such treatments can include inverted "U" shaped bollards, metal piping ribbons, planter, etc. All racks shall be permanently affixed and not obtrusive to pedestrian and vehicular circulation.	YES	
2.6.3	Bicycle linkages to any adjacent bikeways and/or routes shall be provided.	YES	

New Tahoe Area Guidelines and Standards (Bicycle Access)

2.6.4	Site designs shall integrate multimodal transportation improvements (pedestrian, bicycle and transit facilities) consistent with the TRPA/TMPO Regional Transportation Plan, Mobility 2035.		
-------	---------------------------------------------------------------------------------------------------------------------------------------------------------------------------------------------	--	--

2.7 Open Space Areas (DCIS)

2.7.1	High intensity open spaces such as playgrounds, picnic areas, etc. that generally generate noise levels above the normal levels associated with the surrounding neighborhood, should be located so that they are not directly adjacent to noise sensitive uses such as adjoining residences.	YES	
2.7.2	Low Intensity open spaces such as greenways, pedestrian paths, etc. should be located around the perimeter of the site. This can serve as a buffer to the adjacent properties, particularly residential, as well as assist the project in meeting the required on-site landscaping.	YES	
2.7.3	Whenever possible, open space areas should be located on the south and/or west sides of the building and site. This allows the areas to receive maximum sunlight which accelerates melting of snow and ice. Deciduous trees are to be used to provide shade in summer months.	YES	
2.7.4	The location of the open space areas should give consideration to the wind exposure. If necessary appropriate screening features such as walls, landscaping, trellises, etc. should be incorporated into the project design.	YES	

New Tahoe Area Guidelines and Standards (Open Space Areas)

2.7.5	Site plans shall include strategies for protecting undisturbed sensitive lands and, where feasible, establish park or open space corridors connecting undisturbed sensitive areas within Centers to undisturbed areas outside of Centers.		
-------	-------------------------------------------------------------------------------------------------------------------------------------------------------------------------------------------------------------------------------------------	--	--

2.8 Snow Storage (DCIS)

2.8.1	Each development, particularly in the Lake Tahoe portion of the County shall provide an area for snow storage. The snow storage area(s) should be unobstructed by building so that the snow can receive direct sunlight to accelerate the snow melt.	NO	Each development shall incorporate snow melt and/or provide an area for snow storage . The snow storage area should be unobstructed by buildings so that the snow can receive direct sunlight to accelerate the snow melt.
2.8.2	Parking spaces, driveways, drive aisles or sidewalks may not be used for snow storage.	NO	Adequacy and location of snow storage shall be approved by Douglas County.

TRPA Related Snow Storage Design Standards (Ref. Only)

- a. Snow disposal shall comply with Section 60.1.4, TRPA Code of Ordinances (TRPA-Ch.60.1.4)
- b. Commercial, tourist accommodation, public service, recreation and multi-residential projects shall provide, within the project area, snow storage areas of a size adequate to store snow removed from parking, driveway and pedestrian access areas or have arrangements by means of recorded easements or equivalent arrangements to remove and store accumulated snow offsite (TRPA-Ch.36.5.3, B).

3. LANDSCAPE DESIGN

3.1 General (DCIS)

3.1.1	Plants used in project landscaping shall be appropriate for the climate and consistent with the recommended plant list in Appendix B.	NO	Replaced all landscape standards with the Landscape Standards and Guidelines for the South Shore.
3.1.2	The landscape design shall be consistent with Title 20 requirements. Each site shall incorporate at least the minimum percentage of landscaping required by Title 20. Alternative means of meeting this requirement including planter boxes, trellises, landscaping walls, and hardscape may be considered.	NO	Replaced all landscape standards with the Landscape Standards and Guidelines for the South Shore.

3.1.3	Existing trees and natural features are to be preserved and incorporated into the landscaping plan to the extent feasible. Natural areas are not to be disturbed during grading and construction activity.	NO	Replaced all landscape standards with the Landscape Standards and Guidelines for the South Shore.
3.1.4	Landscaping is to be used to define specific areas within a development site such as entrances to sites, buildings, defining edges of various land uses, providing transitions between neighboring properties and provide screening for loading areas and mechanical equipment.	NO	Replaced all landscape standards with the Landscape Standards and Guidelines for the South Shore.
3.1.5	Plants should be in scale with adjacent structure and to be of appropriate size to accomplish intended purposes.	NO	Replaced all landscape standards with the Landscape Standards and Guidelines for the South Shore.
3.1.6	Landscaping shall be perpetually maintained with prompt removal and replacement of dead and diseased plants.	NO	Replaced all landscape standards with the Landscape Standards and Guidelines for the South Shore.
3.1.7	Deciduous trees must be used for street trees, parking lot areas and within planter areas that are designated to provide shade. Evergreen trees are primarily intended to be used for screening and winter color.	NO	Replaced all landscape standards with the Landscape Standards and Guidelines for the South Shore.

3.2 Site Perimeter Landscaping (DCIS)

3.2.1	Unless adjacent sites are integrated (shared parking, access, drive aisles, etc.) or no building setback is provided, perimeter landscaping is required along all property lines of the project site. The landscape planter along the interior property lines shall be a minimum of 6-feet in width or 8-feet when a 2-foot parking space overhang is provided. Where projects are adjacent to residential uses, the landscape planter is to be increased to a minimum of 10 feet.	NO	Replaced all landscape standards with the Landscape Standards and Guidelines for the South Shore.
3.2.2	Parking areas abutting a public street and/or sidewalk shall provide a linear landscape planter a minimum of 10-feet in width. In addition to the general requirements, the planter shall include a combination of berming, solid masonry wall (a minimum of 36-inches in height), dense hedge and include street trees, planted on average every 40 lineal feet of street frontage.	NO	Replaced all landscape standards with the Landscape Standards and Guidelines for the South Shore.
3.2.3	In addition to the general landscape requirements, the perimeter landscaping along the interior property lines shall be separated from adjacent properties by the use of a concrete curb or a redwood header board (minimum 2-inches thick) or other similar materials which can effectively separate ground cover materials.	NO	Replaced all landscape standards with the Landscape Standards and Guidelines for the South Shore.
3.2.4	Perimeter landscaping along interior property lines shall include deciduous and/or evergreen trees, shrubs, perennials or annuals.	NO	Replaced all landscape standards with the Landscape Standards and Guidelines for the South Shore.

3.3 Retention/Detention Basin Landscaping (DCIS)

3.3.1	If the project proposes to utilize on-site retention/detention basin(s), the basin(s) shall be landscaped. The landscaping shall include non-buoyant material such as turf, cobble rock and low spreading ground cover shrubs. The use of buoyant material such as walk-on bark and mulch is not permitted. The landscaping shall be irrigated in accordance with Title 20.	NO	Replaced all landscape standards with the Landscape Standards and Guidelines for the South Shore.
	The landscape design shall provide adequate access for maintenance of the basin.	NO	Replaced all landscape standards with the Landscape Standards and Guidelines for the South Shore.
	Basins facing public rights-of-way shall be fenced utilizing decorative wrought iron or comparable low/no maintenance material.	NO	Replaced all landscape standards with the Landscape Standards and Guidelines for the South Shore.

New Tahoe Area Guidelines and Standards (Landscape Design)

3.1.1	Native vegetation should be utilized whenever possible, consistent with TRPA Landscape Standards and Fire Defensible Space Requirements (Table 5-2: Site Type Recommended Species List, TRPA BMP Handbook).
3.1.2	Vegetation shall be used to screen parking, alleviate long strips of parking space, and accommodate storm water runoff where feasible.
3.1.3	Vegetation should be used to give privacy, reduce glare and heat, deflect wind, muffle noise, prevent erosion, and soften the line of architecture.
3.1.4	Minimize grading and preserve existing vegetation whenever possible.
3.1.5	Landscape designs should respond to the seasonal environmental conditions to encourage outdoor spaces that are comfortable year-round.
3.1.6	Create a quality built environment with the inclusion of amenities such as street furnishing, plantings, art works, and water features to enhance the places that people will walk, gather, or recreate.
3.1.7	Landscapes shall be irrigated to establish planting and provide the correct water levels to support the long term growth of landscape. Irrigation systems must use efficient water methods, group planting into similar hydro-zones, and use moisture sensors to control the use of water.

TRPA Related Landscape Design Standards (Ref. Only)

<p>a. Plant Species Permitted Plant species shall be chosen from the TRPA BMP Handbook, Table 5-2: SITE TYPE RECOMMENDED SPECIES LIST (TRPA-Ch.36.7.1).</p>	
<p>b. Minimum Plant Sizes and Spacing For projects other than single-family home projects, the following sizes and spacing shall be required for woody plant materials at time of planting (TRPA-Ch.36.7.2):</p> <ol style="list-style-type: none"> 1. Trees shall be a minimum six feet tall or one-inch caliper size or diameter at breast height; 2. Shrubs shall be a minimum three-gallon pot size, such that upright shrubs shall have a minimum height of 18 inches and minimum spread of 18 inches, and spreading shrubs shall have a minimum spread of 18 to 24 inches; and 3. Groundcovers shall be a minimum four-inch pot size or one gallon container and shall be a maximum 24 inches on center spacing. 	
<p>c. Accent Vegetation Plant species not found on the TRPA Recommended Native and Adapted Plant List may be used for landscaping as accent plantings. Such plants shall be limited to borders, entryways, flower-beds, and other similar locations to provide accents to the overall native or adapted landscape design (TRPA-Ch.36.7.3).</p>	

4. BUILDING DESIGN

4.1 General (DCIS)

4.1.1	Buildings and additions to existing buildings are to be designed to complement rather than dominate their surroundings. They should be compatible with the surrounding buildings and should incorporate similar architectural elements or facades.	YES	
4.1.2	Predominant exterior building materials must be of superior quality. Exterior walls shall include one or more of the following materials: stucco, brick, wood, native stones or tinted textured masonry units. Smooth-faced concrete block or fabricated metal panels are prohibited as the predominant building material.	NO	Buildings shall employ authentic, textured materials, compatible with the traditional and rustic resort style of the Lake Tahoe Region. Highly reflective materials are considered undesirable, because of their tendency to create uncomfortable glare conditions.
4.1.3	Building height shall be consistent with the Development Code within the respective zoning district and be in scale with the adjoining uses.	NO	Building height shall be consistent with the Tahoe Area Plan Regulations (Chapter 20.703 of the Development Code).
4.1.4	Hotel, resort or institutional uses which propose a passenger loading and unloading area, a porte-cochere, or other similar feature should be provided and may be required. The design of an attached or detached port-cochere must contain the same architectural features and building materials as the primary building.	YES	
4.1.5	The use of standardized "corporate" architectural designs associated with chain or franchise buildings (prevalent with restaurants, service stations and retail stores) is strongly discouraged and alternative designs consistent with this design manual may be required.	YES	

New Tahoe Area Guidelines and Standards (General Building)

4.1.6	Predominate building colors shall be of earth tones, but may be accented with brighter colors. This will provide color variation, punctuation, and a sense of festivity appropriate to the resort destination.
4.1.7	Architectural designs should include functional and visual responses to climate considerations such as solar orientation with warm decks and view windows, protection from prevailing winds, sheltered entries and pedestrian areas, roof overhangs and thermal protections.

4.1.8	Buildings that exemplify "green building" design are desirable. This includes vegetated roofs, rainwater collection systems, designs that preserve existing trees and use of recycled, reclaimed or sustainably harvested materials.
4.1.9	Open spaces, walkways and alleys are encouraged to break up building mass, allow access through developments and create visual breaks.
4.1.10	Larger developments that group retail, hotel, multi-unit residential and/or office buildings are encouraged to shape distinct and memorable public spaces.
4.1.11	If a sign is intended, the building façade shall be designed to accommodate signage, so that tenants will have advertising without detracting from the appearance of the structure.
4.1.12	The maximum allowable height will only be for towers associated with existing gaming properties and will be restricted to five towers. The proposed height will be applicable only if there is an existing high rise tower that is demolished and redeveloped. Redeveloped towers shall improve the visual quality of the area by replacing outdated and deteriorated facilities with newly constructed projects.
4.1.13	Up to four levels of occupied space will be allowed at the setback line from US Hwy. 50.
4.1.14	Redeveloped towers shall include design improvements such as strong pedestrian bases creating an orientation to the street, a mid-section with the potential to incorporate shadow lines and relief, articulation at the roof line aligned with the vernacular character of the region and building articulation to improve on the monolithic square shapes of the existing structures. These design features will have better proportions, comprise variety in design expression, and improve the appearance over the existing designs which do not demonstrate these characteristics.

TRPA Related General Building Design Standards (Ref. Only)

a. Color of Structures (TRPA-Ch.36.6.1, C).	
1. For all structures visible from the Scenic Threshold Travel Routes and from Public Recreation Area and Bicycle Trails identified in the 1993 Lake Tahoe Basin Scenic Resource Evaluation, subdued colors of earthtone ranges shall be used for the primary color of structures.	
2. Colors shall be within a range of natural colors that blend, rather than contrast, with the existing backdrop vegetation and soils color.	
3. For this subparagraph, earthtone colors shall be medium to dark and shall meet the Munsell® Colors set forth in Appendix G, TRPA Approved Earthtone Colors, of the Design Review Guidelines or other color systems that are equivalent to the adopted hues, values, and chromas of Appendix G.	
4. TRPA may grant exceptions to this provision pursuant to Section 67.7, for scenic roadway corridors designated as urban, for unique situations such as site characteristics, or as set forth in subparagraph 83.11.1. Structures in the shoreland that were constructed prior to January 1, 1950, may maintain their historic colors when doing exempt maintenance and repair.	

4.2 Commercial, Institutional and Mixed-Use Building Elevations (DCIS)

4.2.1	Commercial and institutional buildings are to be designed on a "human scale" by using architectural enhancements. Such features should include windows, awning, arcades, provide plazas and courtyards, and/or roof overhangs.	NO	Commercial, Institutional and Mixed-use buildings are to be designed on a "human scale" by using architectural enhancements. Such features should include windows, awnings, arcades, provide plazas and courtyards, and/or roof overhangs.
4.2.2	Commercial and institutional buildings of "box like" appearance are not acceptable. The exterior walls shall be varied in depth and/or direction. Wall planes are not to run in one continuous direction for more than 30 feet without an offset. Facades greater than 100 ft. in length must incorporate recesses (a minimum of 3 feet deep) and projections (minimum 3 feet out) a minimum of 20% the length of the façade. The projections or recesses must be a minimum width of 5 feet.	NO	Commercial, Institutional and Mixed-use buildings of "box like" appearance are prohibited. The exterior walls shall be varied in depth and/or direction.
4.2.3	Varying portions of a building façade, particularly blank walls without windows or varying building materials, shall be articulated by the use of color, arrangement of façade elements, and/or change in material. These elements/materials shall include but are not limited to false windows, awnings, parapet eaves, trellises, arcades, siding, stone, or brick.	YES	
4.2.4	Awnings, parapet eaves or other similar decorative features shall provide a minimum vertical clearance of 8-feet.	YES	
4.2.5	Commercial or institutional metal buildings are not acceptable.	NO	Commercial, Institutional and Mixed-use metal buildings are not acceptable.

New Tahoe Area Guidelines and Standards (Commercial, Institutional and Mixed-Use Building Elevations)

4.2.6	Building design shall be coordinated on all elevations in regards to color, material, form and detailing in order to achieve design harmony and integrity. Parapet walls should be treated as part of the building design, not as unrelated visual elements. Elevations need not look alike for a sense of overall architectural continuity to be present.
4.2.7	Development within the Town Center District shall incorporate buildings with varied heights and densities.

4.2.8	Properties along US Highway 50 with ground level retail and commercial uses shall provide primary pedestrian access directly to the street, in order to ensure an enjoyable and interesting visual experience for pedestrians. Long expanses of inactive building frontage shall be avoided by utilizing architectural elements such as transparent window surfaces, arcades, internal building uses that flow outdoors, and frequent building entry points.
4.2.9	The scoring of vividness, intactness, unity and variety shall be improved with new building elevations and better design in the built environment. The existing conditions have an appearance characterized by repetitive wall surfaces, clutter in the foreground and disassociated design. Redeveloped towers will create opportunities to generate visual interest, articulate the space, and create entries. Replacement of contrasting colors, monotonous wall surfaces, and the outdated design will also be design improvements over the existing conditions.
4.2.10	Dominate blank building walls shall be replaced with an open and more transparent building façade. Shops and restaurants oriented to the street will help establish a lively pedestrian promenade.

4.3 Industrial Building Elevations (DCIS)

4.3.1	Industrial buildings shall be articulated by the use of varying colors, materials and textures. Features such as windows, decorative/false windows, recessed windows, building projections or recesses, and entryway treatments are to be incorporated in the building elevation(s) which face a parking lot or street.	YES	
4.3.2	Industrial metal buildings are permitted provided that any façade, visible from a street, is improved to include at least one of the following, but not limited to: wood or vinyl siding, stucco, brick or stone treatment. Windows shall have a minimum 4 inch trim or decorative window shutters.	YES	

4.4 Roofs (DCIS)

4.4.1	The roof line of any commercial and private recreational building shall not run in a continuous plane for more than 50 feet without offsetting or jogging the roof plane. Roofs must have at least one of the following features around the entire building: 1) stepping parapet roofs concealing flat roofs, 2) overhanging eaves, and/or 3) sloped roof.	NO	Roofs for buildings other than towers, must have at least one of the following features around the entire building: 1) stepping parapet roofs concealing flat roofs, 2) overhanging eaves, and/or 3) sloped roof. Up to 25% of roof surface may be flat.
4.4.2	Height of the building should be varied so that distinctive roof lines are created.	NO	For buildings other than towers, height of the building should be varied so that distinctive roof lines are created.
4.4.3	Buildings utilizing roof-top equipment (including satellite dishes) shall provide parapet walls and/or drop wells to screen the equipment from all sides of the building. The texture and color of the features shall be consistent with the texture and color of the building and shall not be of "picket fence" type screening.	NO	All roof-top equipment including, but not limited to, satellite receiving dishes, communication equipment and HVAC units shall be screened from view.
4.4.4	Reflective, untreated metal roofs are prohibited. All exposed metal surfaces shall be painted in a flat, non-glossy paint to complement or match the color of the exterior roof building material.	YES	

TRPA Related Roof Design Standards (Ref. Only)

a. Roofs, including mechanical equipment and skylights, shall be constructed of non-glare finishes and earthtone colors that minimize reflectivity. For this subparagraph, non-glare earthtone colors are defined as Munsell Colors set forth in Appendix G, TRPA Approved Earthtone Colors, of the Design Review Guidelines, that have a value and chroma of 0-4 or other color systems that are equivalent to the adopted hues, values, and chromas of Appendix G (TRPA-Ch.36.6.1, B).

4.5 Multiple Tenant Buildings (DCIS)

4.5.1	Multi-Building/Tenant developments shall have consistent color schemes and wall textures, roofs, roof slopes, awning, arcades and other similar architectural features.	YES	
4.5.2	Smaller retail stores that are part of a multi-tenant commercial building shall have display windows and separate entrances. The principal building must have a clearly defined, visible customer entrance features such as but not limited to canopies, arcades, arches, wing walls and planters.	YES	

5. SIGNS			
5.1 General (DCIS)			
5.1.1	Every project should be designed with a master sign plan. Provisions for sign placement, sign scale in relationship to the building and sign readability are to be considered in the design.	NO	Replaced all sign standards with the Sign Standards and Guidelines for the South Shore.
5.1.2	In multi-building/tenant complexes all signs shall have a consistent theme through the use of compatible colors, materials, shapes, sizes and types of signs. A master sign plan standardizing the signs shall be provided as part of the development proposal.	NO	Replaced all sign standards with the Sign Standards and Guidelines for the South Shore.
	Signs are to be designed and located to be compatible with the size, shape, color, texture and lighting of the surrounding signs except when signs are non-conforming. Signs are not to compete visually with other signs.	NO	Replaced all sign standards with the Sign Standards and Guidelines for the South Shore.
5.1.4	Wall signs must be integrated into the building and site design and not appear to be added as an afterthought.	NO	Replaced all sign standards with the Sign Standards and Guidelines for the South Shore.
5.1.5	Designs should be simple and easy to read with the number of lettering styles and amount of copy kept to a minimum, preferably giving only the name of the business.	NO	Replaced all sign standards with the Sign Standards and Guidelines for the South Shore.
5.1.6	Monument signs shall be designed so that they complement the architecture of the building/complex. The design of the monument should not be the main focus of the site, but rather blend-in with the site and should contain only the name of the center/business, or major anchor. Monument signs which display multiple tenants within a center are discouraged.	NO	Replaced all sign standards with the Sign Standards and Guidelines for the South Shore.
5.1.7	Monument signs shall be located so that they do not create blind corners, interfere with circulation, parking or traffic safety.	NO	Replaced all sign standards with the Sign Standards and Guidelines for the South Shore.
5.1.8	Monument signs shall include the street number for the site. Street numbers shall be clearly visible from the street frontage during day and night.	NO	Replaced all sign standards with the Sign Standards and Guidelines for the South Shore.
5.1.9	Monument signs should be at eye level of passing motorists.	NO	Replaced all sign standards with the Sign Standards and Guidelines for the South Shore.
New Tahoe Area Guidelines and Standards (Signs)			
5.1.1	Unless modified by these standards, all signs within the South Shore Area Plan must meet the provisions of Section 20.703.180, Signage, of the Douglas County Development Code, as well as Chapter 38, Signs, in the TRPA Code of Ordinances.		
5.1.2	Designs should be simple and easy to read with the number of lettering styles and amount of copy kept to a minimum, preferably giving only the name of the business.		
5.1.3	Signs should be designed and located to be compatible with their surroundings in terms of size, shape, color, texture, and lighting. They should not compete visually with other signs.		
5.1.4	Signs should be integrated into building and site design, and not appear as if added as an afterthought. They should be incorporated into the design of the façade, and should complement the architecture in terms of shape, placement, colors, and materials.		
5.1.6	Reflective, fluorescent, and primary colors should be avoided.		
5.1.7	When possible, signs should be consolidated into unified systems in order to avoid sign clutter along the street, Signage attached to the structure is encouraged.		
5.1.8	Free standing signs should be kept low whenever site and visibility allow. Shrubs placed around base of a freestanding sign integrate it with the ground plane and screen any low level lights.		
5.1.9	Illuminated signs should not be high intensity and glaring in nature. The larger the sign, the lower the level of illumination should be. Illumination of the letters is preferred over illumination of the sign background. It is most preferable the signs be externally illuminated. Light bulbs should not be exposed.		
5.1.10	Signs should be located to respect pedestrian and driver safety. Projecting signs shall clear walkways by eight (8') feet and shall project no closer than two (2') feet from the curb line. Height allowances over driveways, alley and parking areas shall be a minimum of 13'6". Signs should be placed to avoid conflicts with door openings. Signs are not permitted in the road right-of-way. Banners across U.S. Hwy 50 are subject to review and approval by the Nevada Department of Transportation (NDOT).		
5.1.11	Illuminated signs should be positioned so that the light does not shine directly on adjoining properties, cause glare, or shine in the eyes of motorists or pedestrians.		
5.1.12	The back for any one sided regulatory, directional, or informational sign located in a Rural transition or Rural Scenic Highway Corridor should be painted or otherwise colored closely to match the color of the adjacent landscape.		

5.1.13	Signs should have no more than 60% of the sign area in copy. Sign copy includes all letters, numbers, characters, symbols, and other graphics which are part of the sign. The guideline does not apply to signs which consist of individual letters, characters, or other symbols and which have no perimeter or border. Sign Area = X*Y Sign Copy=(A*B)+(C*D) Sign Copy=.60(X*Y).
5.2.1	Every new or redevelopment project with three or more tenants requires a master sign plan. Sign placement, scale, and readability are to be considered in the design.
5.2.2	In multi-building / tenant complexes with three or more tenants all signs shall have a consistent theme through the use of compatible colors, materials, shapes, sizes and types of signs. A master sign plan standardizing the signs shall be provided as part of the development proposal.
5.3.1	Wall signs must be integrated into the building and site design and not appear to be added as an afterthought.
5.4.1	Monument signs shall be designed so that they complement the architecture of the building/ complex. The design of the monument should not be the main focus of the site, but rather blend in with the site and should contain only the name of the center/business, or major anchor.
5.4.2	Monument signs shall be located so that they do not create blind corners, interfere with circulation, parking or traffic safety.
5.4.3	Monument signs shall include the street number for the site. Street numbers shall be clearly visible from the street frontage during day and night.
5.4.4	Monument signs should be at eye level of passing motorists.
5.4.5	Two monument signs (or freestanding signs per Section 38.8.2. of the TRPA Code of Ordinances) may be allowed for the commercial complex located on APNs:1318-23-4-038, -039, -040, and - 041, as long as two signs do not create a traffic safety hazard and the transfer of land to complete the Burke Creek Restoration Project is complete.
5.5.1	A point of interest (wayfinding) signage program should be developed by the Tahoe Chamber of Commerce, in coordination with Douglas County and NDOT, to promote walking and biking to recreation destinations.
5.5.2	One community entry sign shall be located near Kahle Drive and Highway 50, at the entry to the South Shore.

6. LIGHTING

6.1 General (DCIS)

6.1.1	Lighting should be used to provide illumination for the security and safety of on-site areas such as parking, loading/unloading, pedestrian pathways and working areas. Excessive use of lighting fixture is to be avoided.	NO	Lighting should be used to provide illumination for the security and safety of on-site areas such as parking, loading/unloading, pedestrian pathways and working areas. Excessive use of lighting fixtures is prohibited.
6.1.2	Fixture style and location must be compatible with the building's architecture, site design and landscape design. Decorative fixtures are highly recommended and where warranted, may be required. Light fixture style is to be consistent throughout the project.	YES	
6.1.3	Light fixtures shall be located facing away from adjacent sites (particularly residential parcels) so that the light does not spill-over onto abutting properties. Parking and building light fixtures must be cut-off luminaries that have less than 90-degree cut-off so that the light is not emitted horizontally or upward.	YES	
6.1.4	Projects located near residential or open space areas shall use low intensity/wattage lights and all lighting is to be extinguished or reduced in intensity 30 minutes after the close of business.	YES	
6.1.5	Wall pack, flood and other light fixtures which illuminate upwards or horizontally are prohibited.	YES	
6.1.6	A site photometric plan denoting candle illumination on a specific grid, both within the project and off-site, may be required where the project is located adjacent to residential uses and site lighting design indicates a potential for nuisance light impacts to the abutting property.	YES	
6.1.7	The overall height of parking lot light fixtures shall be not more than 15-feet in or within 100-feet of residential districts and not more than 25-feet within non-residential districts. Pedestrian walkway lights shall be of appropriate scale and are encourage to be low intensity bollard type fixtures with a maximum height of 10-feet.	NO	The overall height of parking lot light fixtures shall be not more than 15-feet in or within 100-feet of residential districts and not more than 26-feet (per TRPA code) within non-residential districts. Pedestrian walkway lights shall be of appropriate scale and are encourage to be low intensity bollard type fixtures with a maximum height of 10-feet.
6.1.8	Off-site street lighting may be required over driveways to provide safe entrances and exits.	YES	

New Tahoe Area Guidelines and Standards (Lighting)

6.1.9	Exterior lighting should be minimized to protect dark sky views, yet adequate to provide for public safety, and should be consistent with the architectural design.
6.1.10	Exterior lighting shall utilize cutoff shields that extend below the lighting element to minimize light pollution and stray light.
6.1.11	Lights shall not blink, flash, or change intensity except for temporary public safety signs.
6.1.12	The level of illumination shall be set at the minimum level required for use and even distribution of the light. This will prevent wide contrast levels between light sources and prevent uneven light dispersion. Refer to the following types of lighting and their associated illumination levels. a. Street lighting is intended to address safety concerns along primary and secondary streets for vehicular and pedestrian transportation needs. Levels of illumination for street lighting shall not exceed 3.0 foot candles, measured within one foot of the base at ground level. b. Pedestrian zone lighting is intended for those areas where pedestrians are encouraged to gather such as outdoor plazas, outdoor dining areas, building entries, and pedestrian thoroughfares. Levels of illumination shall not exceed 5.0 foot candles in pedestrian spaces or approved locations unless approved by the Douglas County Planning Commission. c. Safety and security lighting is intended for secondary pedestrian areas or landscape zones that require illumination for security and pedestrian safety. Levels of illumination shall not exceed 2.5 foot candles, measured within one foot of the base at ground level.
6.1.13	Landscape lighting is allowed to highlight elements of the landscape through the use of down lighting with concealed fixtures or fixtures with lens hoods to screen the light source. Landscape lighting fixtures shall be painted with dark colors including brown, gray, black or green.
6.1.14	The entire lighting assembly (pole and fixture) shall be constructed with timber or painted a dark color such as brown, gray, black or green.
6.1.15	Lighting shall be limited to Incandescent, High Pressure Sodium, Metal Halide, Compact Florescent, or LED type lighting in all applications for exterior use.
6.1.16	Lighting which directs light downward shall be used in all applications except for the applications described in the Accent Lighting Standards.
6.1.17	Accent Lighting may be included as part of a lighting plan to prevent dark, uninviting, and oppressive building surfaces above the first floor. Illumination shall be for selective architectural features that serve to landmark, or otherwise highlight design features. Specifically, lighting of distinguished architectural features such as entries, arcades, chimneys, cornices, balconies, exterior trusses, highly textured material, knee braces, enriched architectural facades or landmark features are permitted. Wall lighting of blank wall or repetitive wall facades shall not be permitted. Up to 35% of vertical architectural surfaces may have accent lighting. This may include low angle or upward lighting.

TRPA Related Lighting Design Standards (Ref. Only)

a.	Exterior lights shall not blink, flash, or change intensity. String lights, building or roofline tube lighting, reflective, or luminescent wall surfaces are prohibited (TRPA-Ch.36.8.1, A).
b.	Lighting shall not be attached to trees except for seasonal winter displays. Seasonal winter lighting may be displayed from November 26 through March 1 (TRPA-Ch.36.8.1, B).
c.	Parking lot, walkway, and building lights shall be directed downward (TRPA-Ch.36.8.1, C).
d.	The fixture mounting height shall not exceed the limitations (26 feet) set forth in Chapter 37.6.1 of the TRPA Code of Ordinances (TRPA-Ch.36.8.1, D).
e.	Outdoor lighting shall be used for purposes of illumination only, and shall not be designed for, or used as, an advertising display. Illumination for aesthetic or dramatic purposes of any building or surrounding landscape utilizing exterior light fixtures projected above the horizontal is prohibited (TRPA-Ch.36.8.1, E).
f.	The commercial operation of searchlights for advertising or any other purpose is prohibited (TRPA-Ch.36.8.1, F).
g.	Seasonal lighting displays and lighting for special events that conflict with other provisions of this section may be permitted on a temporary basis pursuant to Chapter 22: Temporary Uses, Structures, and Activities (TRPA-Ch.36.8.1, G).

6.SCREENING

7.1 General (DCIS)

7.1.1	Any outdoor mechanical equipment such as transformers, HVAC units, electrical boxes, back flow preventers, etc. located on the ground must not be visible from the street or the main drive aisle. To the extent possible, use of subterranean vaults is recommended. In any event, such structures shall be screened from view. The method of screening shall be integrated with the adjacent structure in terms of landscaping, wall material/color, shape and size.	YES	
7.1.2	All roof-top equipment shall be screened from view as identified with the architectural guidelines of this manual.	YES	

7.1.3	Storage areas accessory to the permitted use(s) and visible from the public right-of-way, shall be screened from view by the use of a concrete block wall or similar opaque structure. Storage areas not visible from the public right-of-way may be screened by the use of chain-link fence with metal or plastic slating.	YES	
7.1.4	Trash enclosures shall be constructed of masonry block consistent in color and texture with the primary building. Steel grates shall be hung from individual steel posts imbedded in concrete in accordance with Appendix A of the Douglas County Design Criteria and Improvement Standards. Trash enclosures visible from a street shall be screened with landscaping including, but not limited to evergreen trees or columnar shrubs.	YES	
7.1.5	Accessory structures which are used for screening/storage purposes shall be architecturally compatible with the primary building(s).	YES	

TRPA Related Screening Standards (Ref. Only)

a. The architectural design of a project shall include elements that screen from public view all external mechanical equipment, including refuse enclosures, electrical transformer pads and vaults, satellite receiving disks, communication equipment, and utility hardware on roofs, buildings, or the ground (TRPA-Ch.36.6.1, A).

7.2 Walls and Fences (DCIS)

7.2.1	Chain-link fencing with metal, wood or plastic slats is not permitted within the front yards.	YES	
7.2.2	Walls must be designed to blend in and be compatible with the building color and material. Landscaping, including vines, should be planted to soften the wall elevation and limit graffiti to the extent feasible.	YES	
7.2.3	Long wall surfaces must offset and be designed to prevent monotony. Wall and fence design must be consistent with Title 20. Walls and fences not used for screening of storage areas shall provide pedestrian opening if adjacent to sidewalks.	YES	

Appendix B: Site Type Recommended Species List

SITE TYPE RECOMMENDED SPECIES LIST							
Scientific Name ^{1, 2}	Common Name	Wetland	SEZ/Riparian- Wet Meadow	Upland—Generic	Upland—Full Shade	Upland—Full Sun/ Dry Site	Upland— High Disturbance
Grasses, Rushes, and Sedges							
<i>Achnatherum lemmonii</i>	Lemmon's needlegrass			•		•	
<i>Achnatherum occidentale</i>	western needlegrass			•		•	
<i>Agrostis exarata</i>	spike bentgrass		•				
<i>Bromus carinatus</i>	California brome		•	•		•	
<i>Bromus marginatus</i>	mountain brome			•			
<i>Calamagrostis canadensis</i>	bluejoint	•	•				
<i>Carex praegracilis</i>	slender sedge		•				
<i>Danthonia californica</i>	California oatgrass			•			
<i>Deschampsia caespitosa</i>	tufted hairgrass		•				
<i>Deschampsia elongata</i>	slender hairgrass		•				
<i>Elymus elymoides</i>	squirreltail			•		•	
<i>Elymus glaucus</i> ³	blue wildrye	•	•		•		
<i>Elymus trachycaulus</i>	slender wheatgrass,		•	•		•	
<i>Festuca brevipila</i>	hard fescue			•			•
<i>Festuca ovina</i> 'Covar'	sheep fescue, 'Covar'			•		•	•
<i>Festuca rubra</i> ³	red fescue		•		•		•
<i>Festuca rubra ssp. arenaria</i> ³	Boreal creeping red fescue		•		•		•
<i>Glyceria striata</i> ³	fowl mannagrass		•		•		
<i>Hordeum brachyantherum</i>	meadow barley		•				
<i>Hordeum brachyantherum ssp. californicum</i>	California barley		•				
<i>Juncus arcticus ssp. littoralis</i>	mountain rush	•	•				
<i>Juncus effusus</i>	common rush	•	•				
<i>Leymus triticoides</i>	beardless wildrye		•				
<i>Melica californica</i>	California oniongrass			•			
<i>Phalaris arundinacea</i>	reed canarygrass		•				
<i>Phleum alpinum</i>	alpine timothy		•				
<i>Poa ampla</i> , 'Sherman'	big bluegrass, 'Sherman'			•		•	•
<i>Poa secunda</i>	Sandberg bluegrass			•		•	•
<i>Thinopyrum intermedium</i>	intermediate wheatgrass			•			•
<i>Thinopyrum intermedium</i> 'Greenar'	intermediate wheatgrass, 'Greenar'			•			•
<i>Thinopyrum intermedium</i> 'Oahe'	intermediate wheatgrass, 'Oahe'			•			•
Forbs							
<i>Achillea millefolium</i>	common yarrow		•	•			•
<i>Aconitum columbianum</i>	Columbian monkshood		•				
<i>Agastache urticifolia</i>	nettle-leaf giant hyssop		•				
<i>Anaphalis margaritacea</i>	western pearly everlasting		•	•			
<i>Aquilegia formosa</i>	crimson columbine				•		

SITE TYPE RECOMMENDED SPECIES LIST

Scientific Name ^{1,2}	Common Name	Wetland	SEZ/Riparian- Wet Meadow	Upland—Generic	Upland—Full Shade	Upland—Full Sun/ Dry Site	Upland— High Disturbance
<i>Arnica cordifolia</i> ³	heartleaf arnica				•		•
<i>Artemisia douglasiana</i>	Douglas' sagewort		•				
<i>Balsamorhiza sagittata</i>	arrowleaf balsamroot			•			•
<i>Caltha leptosepala</i>	white marsh marigold		•				
<i>Chamerion angustifolium</i>	fireweed		•	•			•
<i>Delphinium glaucum</i> ³	mountain larkspur		•		•		
<i>Epilobium ciliatum</i>	fringed willowherb		•	•			•
<i>Erigeron compositus</i> ⁴	cutleaf daisy			•			
<i>Eriophyllum lanatum</i>	common woolly sunflower			•			
<i>Fragaria virginiana</i>	wild strawberry		•				•
<i>Geranium richardsonii</i>	Richardson's geranium		•				
<i>Geum macrophyllum</i> ³	big leaf avens		•		•		
<i>Geum triflorum</i>	old man's whiskers		•	•			
<i>Gilia capitata</i>	bluehead gilia			•		•	
<i>Heracleum maximum</i>	common cowparsnip		•				
<i>Ipomopsis aggregata</i>	scarlet gilia			•		•	
<i>Linum lewisii</i>	Lewis flax			•		•	
<i>Lotus nevadensis</i>	Nevada bird's-foot trefoil			•			
<i>Lotus unifoliolatus</i> var. <i>unifoliolatus</i>	American bird's-foot trefoil			•			•
<i>Lupinus argenteus</i>	silvery lupine			•		•	•
<i>Lupinus fulcratus</i>	greenstipule lupine			•		•	•
<i>Lupinus grayi</i>	Sierra lupine			•		•	•
<i>Lupinus lepidus</i>	Pacific lupine			•		•	•
<i>Lupinus polyphyllus</i>	bigleaf lupine		•				
<i>Mertensia ciliata</i>	tall fringed bluebells		•				
<i>Mimulus cardinalis</i> ³	scarlet monkey flower		•		•		
<i>Mimulus guttatus</i>	common monkey flower	•	•				
<i>Nasturtium officinale</i>	Watercress	•					
<i>Osmorhiza occidentalis</i>	western sweetroot				•		
<i>Oxyria digyna</i> ⁴	alpine mountainsorrel			•			
<i>Paeonia brownii</i>	Brown's peony			•			
<i>Pedicularis groenlandica</i>	elephant heads		•				
<i>Penstemon rydbergii</i>	Rydberg's penstemon		•				
<i>Penstemon speciosus</i>	royal penstemon			•		•	
<i>Phacelia ramosissima</i>	branching phacelia			•			
<i>Potentilla fruticosa</i>	shrubby cinquefoil		•				
<i>Potentilla glandulosa</i>	sticky cinquefoil		•				•
<i>Potentilla gracilis</i>	slender cinquefoil			•			
<i>Ranunculus occidentalis</i>	western buttercup		•				
<i>Rumex salicifolius</i>	willow dock	•	•				•
<i>Solidago canadensis</i>	Canada goldenrod		•	•			•

SITE TYPE RECOMMENDED SPECIES LIST

Scientific Name ^{1, 2}	Common Name	Wetland	SEZ/Riparian- Wet Meadow	Upland—Generic	Upland—Full Shade	Upland—Full Sun/ Dry Site	Upland— High Disturbance
<i>Symphytotrichum spathulatum</i> var. <i>spathulatum</i>	western mountain aster		•				
<i>Thalictrum fendleri</i>	Fendler's meadow-rue		•				
<i>Urtica dioica</i> ssp. <i>holosericea</i>	stinging nettle		•				•
<i>Wyethia mollis</i>	woolly mule-ears			•		•	•
Subshrubs, Shrubs, and Trees							
<i>Acer circinatum</i>	vine maple				•		
<i>Acer glabrum</i>	Rocky Mountain maple		•				
<i>Alnus incana</i> ssp. <i>tenuifolia</i>	thinleaf alder		•				•
<i>Amelanchier alnifolia</i>	western Serviceberry		•				
<i>Amelanchier utahensis</i>	Utah serviceberry			•			
<i>Arctostaphylos patula</i>	greenleaf manzanita			•		•	•
<i>Arctostaphylos nevadensis</i>	pinemat manzanita			•			
<i>Arctostaphylos uva-ursi</i>	bearberry			•			
<i>Artemisia tridentata</i> ssp. <i>vaseyana</i>	mountain big sagebrush					•	
<i>Calocedrus decurrens</i>	incense cedar			•	•		•
<i>Ceanothus cordulatus</i>	whitethorn			•		•	•
<i>Ceanothus prostratus</i>	prostrate ceanothus, squawbush			•		•	
<i>Ceanothus velutinus</i>	tobaccobrush			•			
<i>Cercocarpus ledifolius</i>	curl-leaf mountain mahogany					•	
<i>Chrysolepis sempervirens</i>	chinquapin			•			
<i>Cornus sericea</i>	redosier dogwood		•				
<i>Ericameria nauseosa</i>	rubber rabbitbrush					•	•
<i>Eriogonum nudum</i>	naked buckwheat					•	•
<i>Eriogonum umbellatum</i>	sulphur-flower buckwheat			•		•	•
<i>Holodiscus discolor</i>	oceanspray creambush		•				
<i>Juniperus occidentalis</i>	western Sierra or Sierra juniper					•	
<i>Lonicera involucrata</i> ³	twinberry		•		•		
<i>Mahonia aquifolium</i>	Oregon grape				•		•
<i>Penstemon deustus</i>	hot-rock penstemon			•		•	
<i>Penstemon newberryi</i>	mountain pride		•	•		•	
<i>Pinus contorta</i> var. <i>murrayana</i> ⁵	Sierra lodgepole pine		•				•
<i>Pinus flexilis</i> ⁶	limber pine					•	
<i>Pinus jeffreyi</i>	Jeffrey pine			•		•	•
<i>Pinus monticola</i>	western white pine			•			
<i>Pinus ponderosa</i>	Ponderosa pine			•		•	•
<i>Populus balsamifera</i> ssp. <i>trichocarpa</i>	black cottonwood		•				
<i>Populus tremuloides</i>	quaking aspen		•				•
<i>Prunus virginiana</i>	western chokecherry		•	•			
<i>Purshia tridentata</i>	antelope bitterbrush			•		•	
<i>Quercus vaccinifolia</i>	huckleberry oak			•	•		

SITE TYPE RECOMMENDED SPECIES LIST

Scientific Name ^{1, 2}	Common Name	Wetland	SEZ/Riparian- Wet Meadow	Upland—Generic	Upland—Full Shade	Upland—Full Sun/ Dry Site	Upland— High Disturbance
<i>Rhus trilobata</i>	skunkbush			•			
<i>Ribes aureum</i>	golden currant		•	•			
<i>Ribes cereum</i>	wax currant			•		•	
<i>Ribes montigenum</i>	gooseberry currant			•			
<i>Ribes nevadense</i>	Sierra currant		•				
<i>Ribes roezlii</i>	Sierra gooseberry			•			
<i>Rosa woodsii</i>	Woods' rose		•	•			•
<i>Rubus parviflorus</i>	thimbleberry		•	•			•
<i>Salix exigua</i>	narrow leaved willow	•	•				
<i>Salix geyeriana</i>	Geyer's willow		•				
<i>Salix lemmonii</i>	Lemmon's willow		•				
<i>Salix lucida ssp. lasiandra</i>	Pacific willow	•	•				
<i>Salix scouleriana</i>	Scouler's willow		•				
<i>Sambucus nigra ssp. cerulea</i>	blue Elderberry		•				
<i>Sambucus racemosa</i>	red elderberry		•				
<i>Sorbus scopulina</i>	Greene's mountain ash		•				
<i>Spiraea douglasii</i>	rose spirea		•				
<i>Spiraea splendens</i> ³	rose meadowsweet		•		•		
<i>Symphoricarpos mollis</i>	creeping snowberry				•		

Notes:

- 1 – Nomenclature follows U.S. Department of Agriculture's PLANTS Database.
- 2 – Names of nonnative species are displayed in bold font.
- 3 – Mesic shaded uplands only
- 4 – Talus, rocky alpine slopes only
- 5 – Invasive of wet meadows
- 6 – Subalpine sites only

